

# Wade™

## Compression Fittings

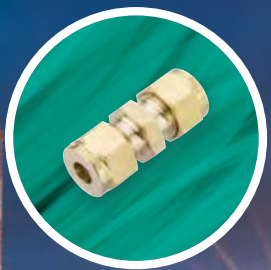
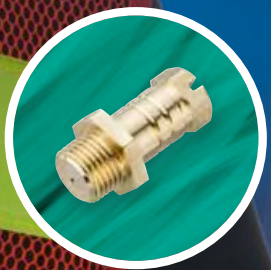

OUR GENIUS IS FITTINGS

## General Information

Wade compression fittings are of brass construction, providing strength and durability. Offering good corrosion resistance from the effects of water and heat they are suitable for use at elevated pressures and temperatures.

The simple design principle enables quick and easy installation with no requirement for special installation skills.

The fittings are resistant to attack from a variety of oils, minerals, acids and gases on hydraulic, pneumatic and instrumentation systems.

All fittings are supplied preassembled which reduces the risk of incorrect assembly.

### Quality Assured

Designed and manufactured to BS 2051 Parts 1 and 2.

### Assembly

Compression fitting assembly comprises a standard body in combination with a variety of compression nut and ring options. This provides mechanically strong and reliable joint connections suitable for a wide range of tube types of various outside diameters and wall thickness.

### Re-makeable Joints

Correctly assembled fittings create a perfect seal that can be broken and remade many times without impairing the efficiency of the joint. This enables easy maintenance and serviceability.

Tube – Tube – Elbow	3
Tube – Tube – Straight	5
Tube – Tube – Tees	10
Tube – Tube – Test point fittings	11
Tube – Male – Banjo	13
Tube – Male – Elbow	15
Tube – Male – Straight	20
Tube – Male – Tee	25
Tube – Female – Elbow	27
Tube – Female – Straight	28
Tube – Female – Tee	33
Plug Cocks & Needle Valves	34
Adaptors & Hose Tails	38
Compression Fittings Accessories	46



# Compression Fittings

## TUBE – TUBE – ELBOW

### FEATURES & BENEFITS

- 90° Elbow configuration
- Enables connection of 2 tubes of the same outside diameter



*Elbow-Imperial*



*Elbow-Metric*

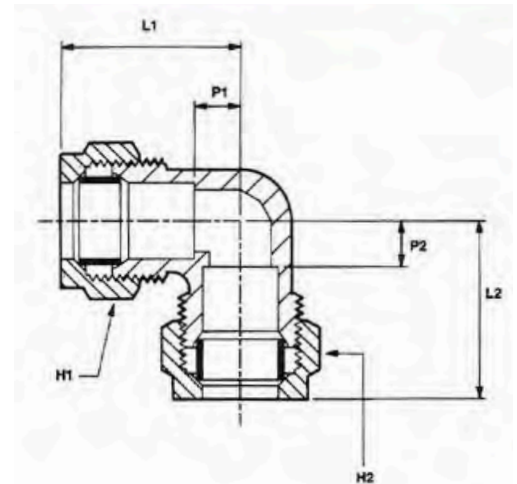

### ELBOW-IMPERIAL

Part No	Tube OD.	Tube OD.	L1 Length	L2 Length	H1 Hex A/F	H2 A/F	P1 Abutment	P2 Abutment
2000	1/8	1/8	0.718	0.718	0.445	0.445	0.25	0.25
2001	3/16	3/16	0.718	0.718	0.445	0.445	0.25	0.25
2003	1/4	1/4	0.812	0.812	0.601	0.601	0.25	0.25
2005	5/16	5/16	0.812	0.812	0.601	0.601	0.25	0.25
2008	3/8	3/8	1.031	1.031	0.82	0.82	0.375	0.375
2011	1/2	1/2	1.093	1.093	0.92	0.92	0.312	0.312

### ELBOW-METRIC

Part No	Tube OD.	Tube OD.	L1 Length	L2 Length	H1 Hex A/F	H2 Hex A/F	P1 Abutment	P2 Abutment
ME104	4	4	19.7	19.7	10	10	8	8
ME106	6	6	23	23	12	12	9.5	9.5
ME108	8	8	25.5	25.5	14	14	10.5	10.5
ME110	10	10	28.5	28.5	19	19	13.5	13.5
ME112	12	12	31	31	22	22	15.5	15.5
ME115	15	15	40.5	40.5	24	24	20	20
ME116	16	16	40	40	27	27	20	20
ME122	22	22	50.5	50.5	36	36	28	28
ME128	28	28	52.7	52.7	41	41	27	27

Every effort has been made to ensure that the information contained in this publication is accurate at the time of publishing. Wade assumes no responsibility or liability for typographical errors or omissions or for any misinterpretation of the information within the publication and reserves the right to change without notice.



# Compression Fittings

## TUBE – TUBE – ELBOW

### FEATURES & BENEFITS

- 90° Elbow configuration
- The standpipe feature allows rotational adjustment enabling the standpipe stem to be jointed with a corresponding compression end, in any alignment within a 360° turning circle



Standpipe Elbow-Imperial

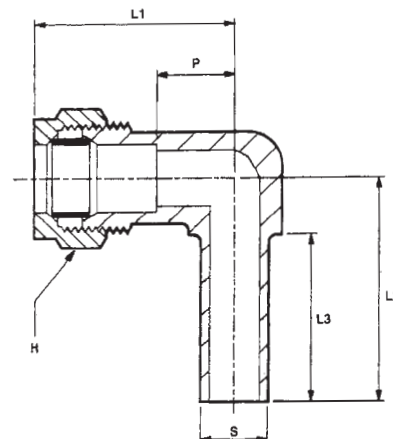

### STANDPIPE ELBOW-IMPERIAL

Part No	Tube OD.	Standpipe Dia.	L1 Length	L2 Length	L3 Length	H Hex A/F	P Abutment
2103	1/4	1/4	1.062	1.187	0.906	0.601	0.5
2105	5/16	5/16	1.062	1.187	0.906	0.601	0.5

Every effort has been made to ensure that the information contained in this publication is accurate at the time of publishing. Wade assumes no responsibility or liability for typographical errors or omissions or for any misinterpretation of the information within the publication and reserves the right to change without notice.

# Compression Fittings

## TUBE – TUBE – STRAIGHT

### FEATURES & BENEFITS

- In-line configuration
- Enables connection of 2 tubes of the same outside diameter



Equal Ended Coupling -Imperial



Equal Ended Coupling -Metric

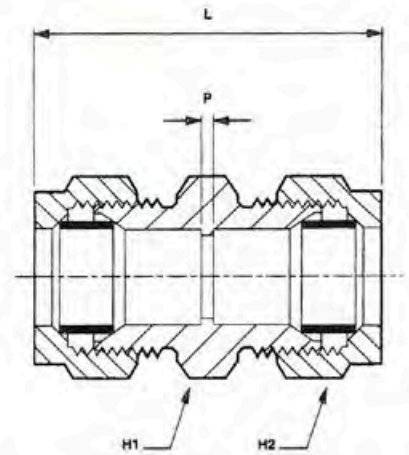

### EQUAL ENDED COUPLING -IMPERIAL

Part No	Tube OD.	L Length	H1 Hex A/F	H2 Hex A/F	P Abutment
1040	1/8	1.093	0.445	0.445	0.156
1041	3/16	1.093	0.445	0.445	0.156
1043	1/4	1.25	0.601	0.601	0.125
1045	5/16	1.25	0.601	0.601	0.125
1048	3/8	1.406	0.71	0.82	0.093
1051	1/2	1.625	0.92	0.92	0.062
1053	5/8	1.875	1.1	1.2	0.125
1054	3/4	1.937	1.2	1.39	0.125
1057	1	2.125	1.48	1.67	0.125

### EQUAL ENDED COUPLING -METRIC

Part No	Tube OD.	L Length	H1 Hex A/F	H2 Hex A/F	P Abutment
MCI04	4	33	10	10	9
MCI05	5	37	11	12	9
MCI06	6	36	11	12	9
MCI08	8	40	13	14	10
MCI10	10	42	17	19	12
MCI12	12	43.5	19	22	12.5
MCI15	15	57.5	22	24	16.5
MCI16	16	57.5	24	27	17.5
MCI20	20	60	30	32	19
MCI22	22	64	32	36	19
MCI28	28	67.5	41	41	16

Every effort has been made to ensure that the information contained in this publication is accurate at the time of publishing. Wade assumes no responsibility or liability for typographical errors or omissions or for any misinterpretation of the information within the publication and reserves the right to change without notice.

# Compression Fittings

## TUBE – TUBE – STRAIGHT

### FEATURES & BENEFITS

- In-line configuration
- Enables connection of 2 tubes of different outside diameters
- Unequal (reduced) fitting which enables connection of an imperial outside tube diameter to a metric outside diameter tube
- Existing imperial pipework needs to be converted to metric



Equal Ended Coupling -Imperial

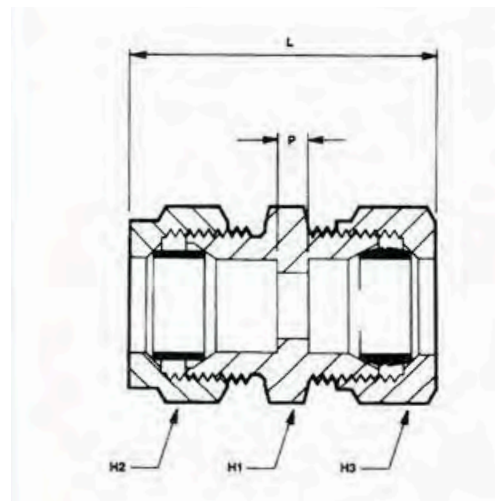

## IMPERIAL TO METRIC COUPLING

Part No	Tube OD.	Tube OD.	L Length (mm)	H1 Hex A/F (mm)	H2 Hex A/F	H3 Hex A/F (mm)	P Abutment (mm)
MCI06/3	1/4	6	38	17	0.601"	12	6.7
MCI10/8	3/8	10	43.5	19	0.820"	19	8.5
MCI15/8	3/8	15	50	22	0.820"	24	9.9

Every effort has been made to ensure that the information contained in this publication is accurate at the time of publishing. Wade assumes no responsibility or liability for typographical errors or omissions or for any misinterpretation of the information within the publication and reserves the right to change without notice.

# Compression Fittings

## TUBE – TUBE – STRAIGHT

### FEATURES & BENEFITS

- In-line configuration
- Enables connection of 2 tubes of different outside diameters



*Unequal Coupling-Imperial*



*Unequal Coupling-Metric*

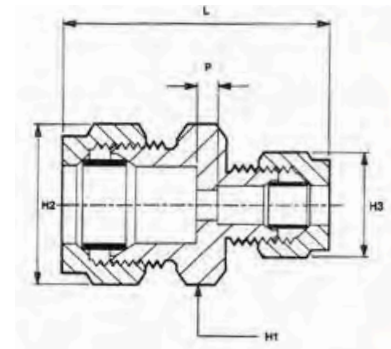

### UNEQUAL COUPLING-IMPERIAL

Part No	Tube OD.	Tube OD.	L Length	H1 Hex A/F	H2 Hex A/F	H3 Hex A/F	P Abutment
4041/0	3/16	1/8	1.125	0.445	0.445	0.445	0.156
4043/0	1/4	1/8	1.187	0.525	0.601	0.445	0.156
4043/1	1/4	3/16	1.187	0.525	0.601	0.445	0.156
4045/1	5/16	3/16	1.187	0.525	0.601	0.445	0.156
4045/3	5/16	1/4	1.25	0.601	0.601	0.601	0.125
4048/3	3/8	1/4	1.375	0.71	0.82	0.601	0.156
4048/5	3/8	5/16	1.375	0.71	0.82	0.601	0.156
4051/3	1/2	1/4	1.5	0.92	0.92	0.601	0.156
4051/5	1/2	5/16	1.5	0.92	0.92	0.601	0.156
4051/8	1/2	3/8	1.562	0.92	0.92	0.82	0.125

### UNEQUAL COUPLING-METRIC

Part No	Tube OD.	Tube OD.	L Length	H1 Hex A/F	H2 Hex A/F	H3 Hex A/F	P Abutment
MCI06/104	6	4	34.5	11	12	10	9
MCI08/105	8	5	37	13	14	12	10
MCI08/106	8	6	38	13	14	12	10
MCI10/106	10	6	39.5	17	19	12	11
MCI10/108	10	8	41	17	19	14	11
MCI12/108	12	8	41.5	19	22	14	11.5
MCI15/108	15	8	49.5	22	24	14	14
MCI15/110	15	10	50.5	22	24	19	15

Every effort has been made to ensure that the information contained in this publication is accurate at the time of publishing. Wade assumes no responsibility or liability for typographical errors or omissions or for any misinterpretation of the information within the publication and reserves the right to change without notice.

# Compression Fittings

## TUBE – TUBE – STRAIGHT

### FEATURES & BENEFITS

- In-line configuration
- Enables connection of 2 tubes of different outside diameter
- Designed to connect tubes on either side of a bulkhead panel.
- Provided with a simple locknut mechanism the fitting can be secured and locked in place through the panel

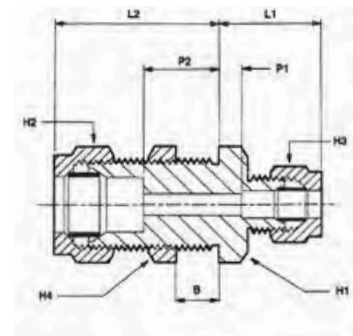

*Unequal Bulkhead Coupling-Imperial*

### UNEQUAL BULKHEAD COUPLING-IMPERIAL

Part No	Tube OD.	Tube OD.	L1 Length	L2 Length	H1 & H2 Hex A/F	H3 Hex A/F	H4 Hex A/F	P1 Abutment	P2 Abutment	B Max Bulkhead	Bulkhead Hole Dia
4043/0L6	1/4	1/8	0.656	1.125	0.601	0.445	0.71	0.187	0.562	3/8	0.531
4045/3/L3	5/16	1/4	0.781	0.937	0.601	0.601	0.71	0.218	0.375	3/16	0.531

Every effort has been made to ensure that the information contained in this publication is accurate at the time of publishing. Wade assumes no responsibility or liability for typographical errors or omissions or for any misinterpretation of the information within the publication and reserves the right to change without notice.



# Compression Fittings

## TUBE – TUBE – STRAIGHT

### FEATURES & BENEFITS

- In-line configuration
- Enables connection of 2 tubes of the same outside diameter
- Designed to connect tubes on either side of a bulkhead panel
- Provided with a simple locknut mechanism the fitting can be secured and locked in place through the panel



Equal Ended Bulkhead Coupling-Imperial



Equal Ended Bulkhead Coupling-Metric

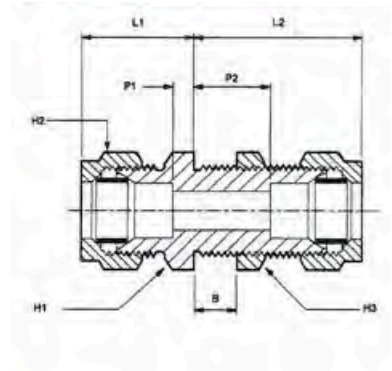

### EQUAL ENDED BULKHEAD COUPLING-IMPERIAL

Part No	Tube OD.	L1 Length	L2 Length	H1 Hex A/F	H2 Hex A/F	H3 Hex A/F	P1 Abutment	P2 Abutment	B Max Bulkhead	Bulkhead Hole Dia
I040L4	1/8	0.625	0.906	0.445	0.445	0.525	0.156	0.437	1/4	0.391
I041L6	3/16	0.625	1.093	0.445	0.445	0.525	0.156	0.625	3/8	0.391
I043L3	1/4	0.718	0.937	0.601	0.601	0.710	0.156	0.375	3/16	0.531
I043L6	1/4	0.718	1.125	0.601	0.601	0.710	0.156	0.562	3/8	0.531
I043L10	1/4	0.718	1.375	0.601	0.601	0.710	0.156	0.812	5/8	0.531
I045L3	5/16	0.718	0.937	0.601	0.601	0.710	0.156	0.375	3/16	0.531
I045L6	5/16	0.718	1.125	0.601	0.601	0.710	0.156	0.562	3/8	0.531
I045L10	5/16	0.718	1.375	0.601	0.601	0.710	0.156	0.812	5/8	0.531
I048L6	3/8	0.960	1.218	0.820	0.820	0.820	0.187	0.562	3/8	0.672
I048L10	3/8	0.960	1.468	0.820	0.820	0.820	0.187	0.812	5/8	0.672
I048L12	3/8	0.960	1.718	0.820	0.820	0.820	0.187	1.062	3/4	0.672
I051L8	1/2	0.906	1.406	1.010	0.920	1.010	0.125	0.625	1/2	0.844
I051L12	1/2	0.906	1.656	1.010	0.920	1.010	0.125	0.875	3/4	0.844

### EQUAL ENDED BULKHEAD COUPLING-METRIC

Part No	Tube OD.	L1 Length	L2 Length	H1 Hex A/F	H2 Hex A/F	H3 Hex A/F	P1 Abutment	P2 Abutment	B Max Bulkhead	Bulkhead Hole Dia
MB106/L10	6	20	30	12	12	12	6.5	16.5	10	11
MB108/L10	8	22.5	31.5	14	14	14	7.5	16.5	10	13
MB110/L10	10	24	33.5	19	19	19	9	18.5	10	17
MB112/L10	12	25.5	34	22	22	22	10	18.5	10	19
MB115/L10	15	33	40.5	24	24	24	12.5	20	10	21
MB122/L12	22	36.5	46.5	36	36	36	14	24	12	31
MB128/L12	28	37.7	49.7	41	41	41	12	24	12	37

Every effort has been made to ensure that the information contained in this publication is accurate at the time of publishing. Wade assumes no responsibility or liability for typographical errors or omissions or for any misinterpretation of the information within the publication and reserves the right to change without notice.

# Compression Fittings

## TUBE – TUBE – STRAIGHT

### FEATURES & BENEFITS

- A female threaded bulkhead adaptor featuring a simple locking mechanism
- When locked in to place through the bulkhead panel the fitting provides a BSP parallel female threaded port on either side allowing connection with BSP parallel male stud couplings



Female Bulkhead

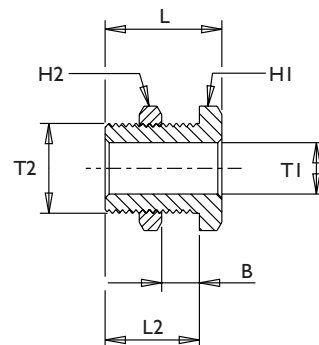

### FEMALE BULKHEAD

Part No	T1 BSP Female Thread	L1 Length	L2 Length	H1 Hex A/F	H2 Hex A/F	B Max Bulkhead	T2 Male Thread	Bulkhead Hole Dia
MB 082/L10	1/8	20	15	19	19	10	M16 x 1.5	17
MB 162/L16	1/4	26	21	24	24	16	M20 x 1.5	21
MB 242/L15	3/8	27	21	27	27	15	M24 x 1.5	25
MB 322/L21	1/2	35	28	36	36	21	M30 x 1.5	31

## TUBE – TUBE – TEES

### FEATURES & BENEFITS

- 'T' configuration
- Enables connection of 3 tubes of the same outside diameter



Equal Tee-Imperial



Equal Tee-Metric

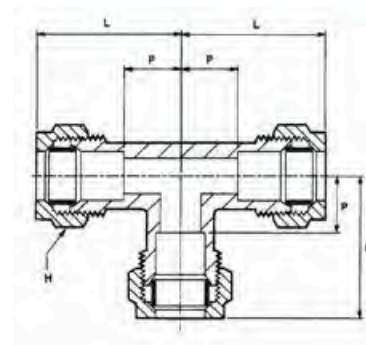

### EQUAL TEE-IMPERIAL

Part No	Tube OD.	L Length	H Hex A/F	P Abutment
2040	1/8	0.718	0.445	0.25
2041	3/16	0.718	0.445	0.25
2043	1/4	0.812	0.601	0.25
2045	5/16	0.812	0.601	0.25
2048	3/8	1.031	0.82	0.375
2051	1/2	1.093	0.92	0.312

### EQUAL TEE-METRIC

Part No	Tube OD.	L Length	H Hex A/F	P Abutment
MT104	4	20	10	8
MT106	6	23	12	9.5
MT108	8	25.5	14	10.5
MT110	10	28.5	19	13.5
MT112	12	31	22	15.5
MT115	15	40.5	24	20
MT116	16	40	27	20
MT122	22	50.5	36	28
MT128	28	52.7	41	27

Every effort has been made to ensure that the information contained in this publication is accurate at the time of publishing. Wade assumes no responsibility or liability for typographical errors or omissions or for any misinterpretation of the information within the publication and reserves the right to change without notice.

# Compression Fittings

## TUBE – TUBE – TEST POINT FITTINGS

### FEATURES & BENEFITS

- Range includes; in-line tube to tube unions, tube to tube elbows & 1/8" BSP taper male nipples
- Designed to provide a pressure test point for LPG and natural gas systems
- Conform to BS 4161
- Compression ends are designed and manufactured to BS 2051
- Wade test point fittings are widely used on caravan and boat pipe installations where EU regulations stipulate the fitting of test points on gas system pipework. For example,

The Boat Safety Scheme, (owned by the Canal & River Trust and Environment Agency), require that All LPG systems must be fitted with one of the following means to determine gas tightness:

**A:** a readily accessible proprietary test point on an appliance

**B:** a readily accessible proprietary test point fitted in the pipework

**C:** a bubble tester installed in a cylinder locker or cylinder housing



Test Point Union-Imperial



Test Point Union-Metric

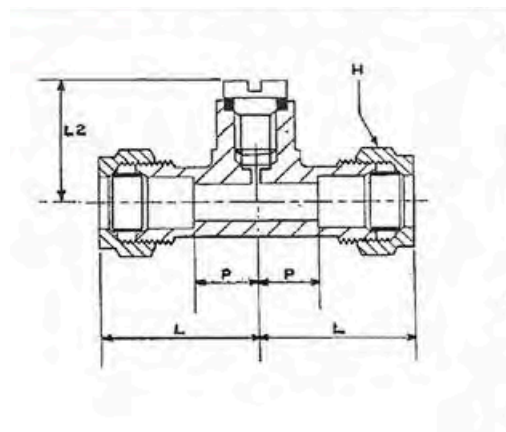

### TEST POINT UNION-IMPERIAL

Part No	Tube OD.	L Length	L2 Length	H Hex A/F	P Abutment
TP2043B	1/4	0.812	0.812	0.601	0.25
TP2045B	5/16	0.812	0.812	0.601	0.25
TP2048B	3/8	1.031	1.031	0.82	0.375
TP2051B	1/2	1.093	1.093	0.92	0.312

### TEST POINT UNION-METRIC

Part No	Tube OD.	L Length	L2 Length	H Hex A/F	P Abutment
MTP1208B	8	20.5	20.5	17	6.3
MTP1210B	10	26	26	19	9.5
MTP1212B	12	27.5	27.5	22	8
MTP1215B	15	TBC	TBC	24	20

Every effort has been made to ensure that the information contained in this publication is accurate at the time of publishing. Wade assumes no responsibility or liability for typographical errors or omissions or for any misinterpretation of the information within the publication and reserves the right to change without notice.

# Compression Fittings



Test Point Elbow-Imperial

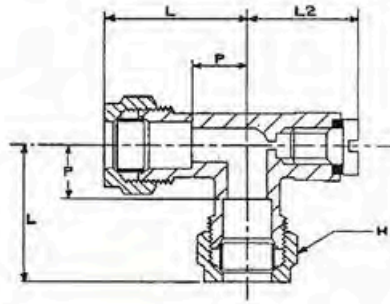

## TEST POINT ELBOW-IMPERIAL

Part No	Tube OD.	L Length	L2 Length	H Hex A/F	P Abutment
TP2043E	1/4	0.812	0.812	0.601	0.25
TP2045E	5/16	0.812	0.812	0.601	0.25
TP2048E	3/8	1.031	1.031	0.82	0.375
TP2051E	1/2	1.093	1.093	0.92	0.312



Test Point Nipple

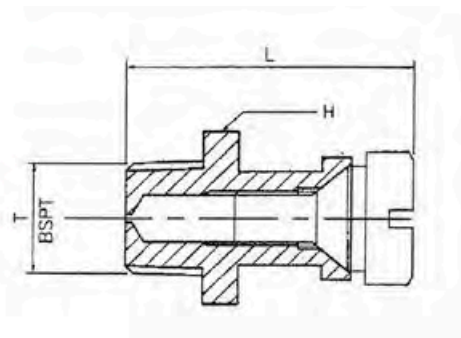

## TEST POINT NIPPLE

Part No	T BSPT Male Thread	L Length	H Hex A/F
SK4157COMPLE	1/8	0.95	0.512

Every effort has been made to ensure that the information contained in this publication is accurate at the time of publishing. Wade assumes no responsibility or liability for typographical errors or omissions or for any misinterpretation of the information within the publication and reserves the right to change without notice.

# Compression Fittings

## TUBE – MALE – BANJO

### FEATURES & BENEFITS

- The construction incorporates a brass body and a steel bolt for additional strength
- The design enables connection of tube at 90° to the BSP parallel male stud thread
- The banjo coupling allows rotational adjustment. During installation, (before fully tightening the hexagon head on the banjo bolt), the tube outlet (compression end) can be aligned in any direction within a 360° turning circle. This provides a distinct advantage over a standard BSP parallel male stud elbow which does not allow the same degree of adjustment
- Banjo couplings are commonly used on automotive fuel, oil and hydraulic applications such as brake and clutch systems



Single Banjo Coupling-With Steel Bolt-Imperial



Single Banjo Coupling-With Steel Bolt-Metric

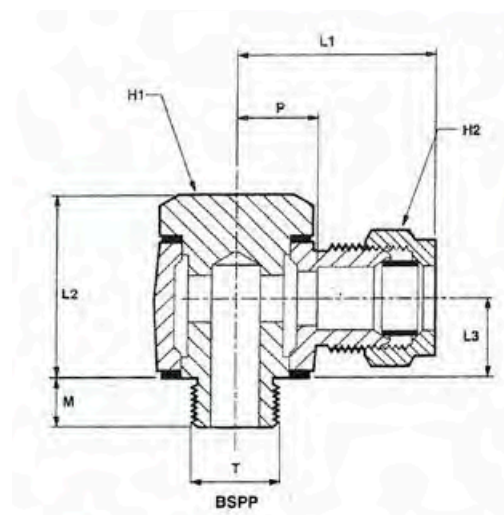

### SINGLE BANJO COUPLING-WITH STEEL BOLT-IMPERIAL

Part No	Tube OD.	T BSPP Male Thread	M Stud Length	L1 Length	L2 Length	L3 Length	H1 Hex A/F	H2 Hex A/F	P Abutment
3503	1/4	1/4	0.343	1.062	0.968	0.421	0.71	0.601	0.5
6505/1	5/16	1/8	0.312	1.062	0.968	0.421	0.71	0.601	0.5
3505	5/16	1/4	0.343	1.062	0.968	0.421	0.71	0.601	0.5

### SINGLE BANJO COUPLING-WITH STEEL BOLT-METRIC

Part No	Tube OD.	T BSPP Male Thread	M Stud Length	L1 Length	L2 Length	L3 Length	H1 Hex A/F	H2 Hex A/F	P Abutment
MJ108/081	8	1/8	10.5	26.5	24	9.5	14	14	11.5
MJ108/161	8	1/4	16	30.5	31.5	13	19	14	15.5
MJ112/241	12	3/8	16	33.5	38.5	16	22	22	18
MJ112/321	12	1/2	21	34	45.5	19.5	27	22	18.5

Every effort has been made to ensure that the information contained in this publication is accurate at the time of publishing. Wade assumes no responsibility or liability for typographical errors or omissions or for any misinterpretation of the information within the publication and reserves the right to change without notice.



# Compression Fittings



Project: Shell, Stanlow  
Specification: Wade Compression Fittings

Technical Helpline: +44 (0) 1473 277 460  
E: [wadesales@cranebsu.com](mailto:wadesales@cranebsu.com) W: [www.wadefittings.com](http://www.wadefittings.com)

Wade™

14

# Compression Fittings

## TUBE – MALE – ELBOW

### FEATURES & BENEFITS

- 90° Elbow configuration with an API male stud thread
- Enables tube connection to a mating API or NPT female threaded port



Male Stud Elbow API-Imperial



Male Stud Elbow API-Metric

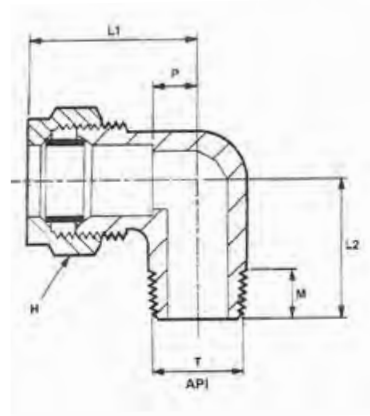

### MALE STUD ELBOW API-IMPERIAL

Part No	Tube OD.	T API Male Thread	M Stud Length	L1 Length	L2 Length	H Hex A/F	P Abutment
5023/1API	1/4	1/8	0.375	0.937	0.781	0.601	0.375
2023API	1/4	1/4	0.562	0.937	0.968	0.601	0.375
5028/3API	3/8	1/4	0.562	1.093	1.093	0.82	0.437
2028API	3/8	3/8	0.562	1.093	1.093	0.82	0.437
2031API	1/2	1/2	0.75	1.218	1.312	0.92	0.437

### MALE STUD ELBOW API-METRIC

Part No	Tube OD.	T API Male Thread	M Stud Length	L1 Length	L2 Length	H Hex A/F	P Abutment
ME106/085	6	1/8	9.5	24	20.5	12	10.5
ME106/165	6	1/4	10.5	24	20.5	12	10.5
ME108/165	8	1/4	10.5	25.5	20.5	14	10.5
ME110/165	10	1/4	10.5	28.5	23.5	19	13.5

Every effort has been made to ensure that the information contained in this publication is accurate at the time of publishing. Wade assumes no responsibility or liability for typographical errors or omissions or for any misinterpretation of the information within the publication and reserves the right to change without notice.

# Compression Fittings

## TUBE – MALE – ELBOW

### FEATURES & BENEFITS

- 90° Elbow configuration with a BSP taper male stud thread
- Enables tube connection to a mating BSP taper or BSP parallel BS2I female threaded port



Male Stud Elbow BSPT-Imperial

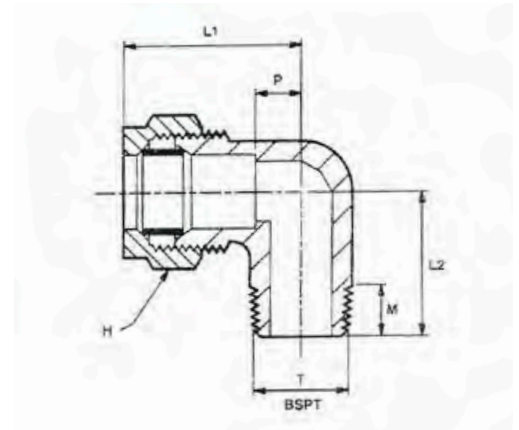

### MALE STUD ELBOW BSPT-IMPERIAL

Part No	Tube OD.	T BSPT Male Thread	M Stud Length	L1 Length	L2 Length	H Hex A/F	P Abutment
8020	1/8	1/8	0.375	0.75	0.718	0.445	0.281
8021	3/16	1/8	0.375	0.75	0.718	0.445	0.281
8023/1	1/4	1/8	0.375	0.937	0.718	0.601	0.375
8023	1/4	1/4	0.531	0.937	0.937	0.601	0.375
8023/8	1/4	3/8	0.531	1.062	1.093	0.601	0.5
8025/1	5/16	1/8	0.375	0.937	0.718	0.601	0.375
8025	5/16	1/4	0.531	0.937	0.937	0.601	0.375
8025/8	5/16	3/8	0.531	1.062	1.093	0.601	0.5
8028/1	3/8	1/8	0.375	1.093	0.937	0.82	0.437
8028/3	3/8	1/4	0.531	1.093	1.093	0.82	0.437
8028	3/8	3/8	0.531	1.093	1.093	0.82	0.437
8028/11	3/8	1/2	0.687	1.218	1.312	0.82	0.562
8031/8	1/2	3/8	0.531	1.218	1.125	0.92	0.437
8031	1/2	1/2	0.687	1.218	1.312	0.92	0.437
8033/11	5/8	1/2	0.687	1.5	1.5	1.2	0.625
8034	3/4	3/4	0.687	1.687	1.718	1.39	0.781

Every effort has been made to ensure that the information contained in this publication is accurate at the time of publishing. Wade assumes no responsibility or liability for typographical errors or omissions or for any misinterpretation of the information within the publication and reserves the right to change without notice.



# Compression Fittings

## TUBE – MALE – ELBOW

### FEATURES & BENEFITS

- 90° Elbow configuration with a BSP taper male stud thread
- Enables tube connection to a mating BSP taper or BSP parallel BS21 female threaded port



Male Stud Elbow BSPT-Metric

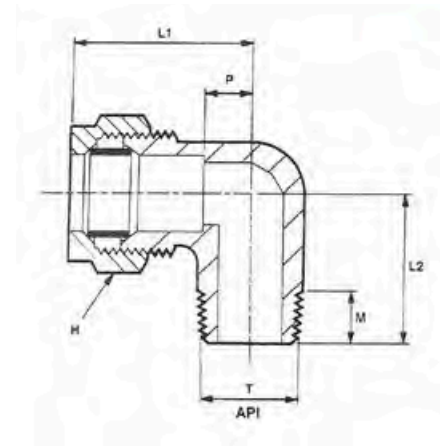

### MALE STUD ELBOW BSPT-METRIC

Part No	Tube OD.	T BSPT Male Thread	M Stud Length	L1 Length	L2 Length	H Hex A/F	P Abutment
ME104/083	4	1/8	7	22.5	17	10	10.5
ME106/083	6	1/8	7	24	17	12	10.5
ME106/163	6	1/4	10.5	24	20.5	12	10.5
ME108/083	8	1/8	7	25.5	17	14	10.5
ME108/163	8	1/4	10.5	25.5	20.5	14	10.5
ME108/243	8	3/8	11	28.5	24	14	13.5
ME110/163	10	1/4	10.5	28.5	23.5	19	13.5
ME110/243	10	3/8	11	28.5	24	19	13.5
ME110/323	10	1/2	14.5	36.5	32.5	19	21.5
ME112/163	12	1/4	10.5	31	25.5	22	15.5
ME112/243	12	3/8	11	31	26	22	15.5
ME112/323	12	1/2	14.5	34	32.5	22	18.5
ME115/243	15	3/8	11	40.5	29	24	20
ME115/323	15	1/2	14.5	40.5	32.5	24	20
ME116/323	16	1/2	11	40	29	27	20
ME120/483	20	3/4	16	43.5	37	32	23
ME122/483	22	3/4	16	50.5	42	36	28
ME125/483	25	3/4	16	50.5	42	41	28
ME125/643	25	1	18.5	50.5	44.5	41	28

Every effort has been made to ensure that the information contained in this publication is accurate at the time of publishing. Wade assumes no responsibility or liability for typographical errors or omissions or for any misinterpretation of the information within the publication and reserves the right to change without notice.

# Compression Fittings

## TUBE – MALE – ELBOW

### FEATURES & BENEFITS

- 90° Elbow configuration with a BSP parallel male stud thread
- Enables tube connection to a mating BSP parallel BS2779 female threaded port



Male Stud Elbow BSP Parallel-Imperial

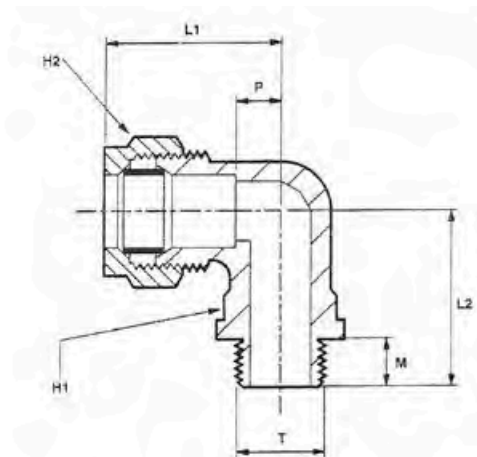

### MALE STUD ELBOW BSP PARALLEL-IMPERIAL

Part No	Tube OD.	T BSPP Male Thread	M Stud Length	L1 Length	L2 Length	H1 Hex A/F	H2 Hex A/F	P Abutment
5023/1	1/4	1/8	0.312	1.062	1	0.445	0.601	0.5
2023	1/4	1/4	0.343	1.062	1.062	0.445	0.601	0.5
5023/8	1/4	3/8	0.375	1.218	1.25	0.601	0.601	0.656
2025	5/16	1/4	0.343	1.062	1.062	0.445	0.601	0.5
2028	3/8	3/8	0.375	1.25	1.25	0.601	0.82	0.593
2031	1/2	1/2	0.437	1.375	1.375	0.71	0.92	0.593

Every effort has been made to ensure that the information contained in this publication is accurate at the time of publishing. Wade assumes no responsibility or liability for typographical errors or omissions or for any misinterpretation of the information within the publication and reserves the right to change without notice.



# Compression Fittings

## TUBE – MALE – ELBOW

### FEATURES & BENEFITS

- 90° Elbow configuration with a BSP parallel male stud thread
- Enables tube connection to a mating BSP parallel BS2779 female threaded port



Male Stud Elbow BSP Parallel-Metric

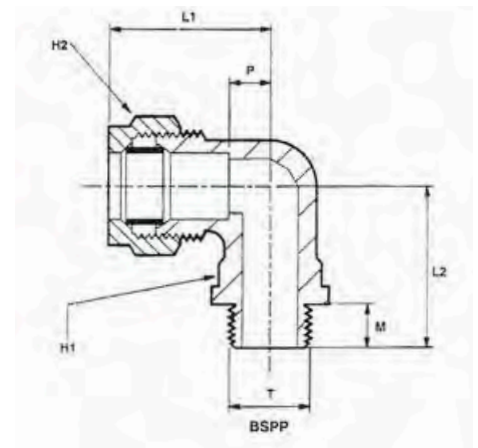

### MALE STUD ELBOW BSP PARALLEL-METRIC

Part No	Tube OD.	T BSPP Male Thread	M Stud Length	L1 Length	L2 Length	H1 Hex A/F	H2 Hex A/F	P Abutment
ME106/081	6	1/8	7	26.5	23.7	10	12	13.5
ME106/161	6	1/4	10.5	27	29.2	10	12	13.5
ME108/081	8	1/8	7	28.5	23.7	10	14	13.5
ME108/161	8	1/4	10.5	28.5	29.2	10	14	13.5
ME110/161	10	1/4	10.5	31.5	32	12	19	16.5
ME110/241	10	3/8	11	31.5	34.5	12	19	16.5
ME112/241	12	3/8	11	32	31.2	17	22	16.5
ME112/321	12	1/2	14.5	34	38.5	19	22	18.5

Every effort has been made to ensure that the information contained in this publication is accurate at the time of publishing. Wade assumes no responsibility or liability for typographical errors or omissions or for any misinterpretation of the information within the publication and reserves the right to change without notice.

# Compression Fittings

## TUBE – MALE – STRAIGHT

### FEATURES & BENEFITS

- In-line configuration with an API male stud thread
- Enables tube connection to a mating API or NPT female threaded port



Male Stud Coupling API-Imperial



Male Stud Coupling API-Metric

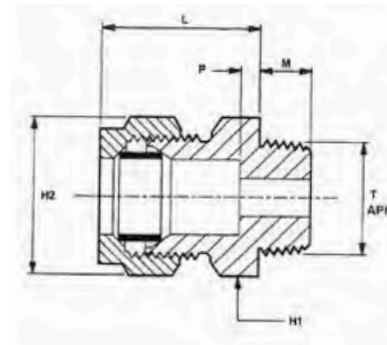

### MALE STUD COUPLING API-IMPERIAL

Part No	Tube OD.	T API Male Thread	M Stud Length	L Length	H1 Hex A/F	H2 Hex A/F	P Abutment
4061/3API	3/16	1/4	0.562	0.656	0.601	0.445	0.187
4063/1API	1/4	1/8	0.375	0.718	0.525	0.601	0.156
1063API	1/4	1/4	0.562	0.718	0.601	0.601	0.156
4063/8API	1/4	3/8	0.562	0.781	0.71	0.601	0.218
4063/11API	1/4	1/2	0.75	0.781	0.92	0.601	0.218
1065API	5/16	1/4	0.562	0.718	0.601	0.601	0.156
4068/1API	3/8	1/8	0.375	0.843	0.71	0.82	0.187
4068/3API	3/8	1/4	0.562	0.843	0.71	0.82	0.187
1068API	3/8	3/8	0.562	0.843	0.71	0.82	0.187
4068/11API	3/8	1/2	0.75	0.843	0.92	0.82	0.25
4071/3API	1/2	1/4	0.562	0.906	0.92	0.92	0.125
4071/8API	1/2	3/8	0.562	0.906	0.92	0.92	0.125
1071API	1/2	1/2	0.75	0.906	0.92	0.92	0.125

### MALE STUD COUPLING API-METRIC

Part No	Tube OD.	T API Male Thread	M Stud Length	L Length	H1 Hex A/F	H2 Hex A/F	P Abutment
MC106/085	6	1/8	9.5	20.75	11	12	6
MC106/165	6	1/4	14	22	14	12	7.75
MC106/245	6	3/8	14.5	23.75	19	12	8.75
MC106/325	6	1/2	19	25	22	12	10
MC108/165	8	1/4	14	23.5	14	14	7.75
MC110/165	10	1/4	14	23.5	17	19	8.5
MC110/245	10	3/8	14.5	25.25	19	19	8.75
MC110/325	10	1/2	19	26.5	22	19	10.5
MC112/165	12	1/4	14	25.7	19	22	8.5
MC112/245	12	3/8	14.5	25.75	19	22	8.75

Every effort has been made to ensure that the information contained in this publication is accurate at the time of publishing. Wade assumes no responsibility or liability for typographical errors or omissions or for any misinterpretation of the information within the publication and reserves the right to change without notice.

# Compression Fittings

## TUBE – MALE – STRAIGHT

### FEATURES & BENEFITS

- In-line configuration with a BSP taper male stud thread
- Enables tube connection to a mating BSP taper or BSP parallel BS21 female threaded port

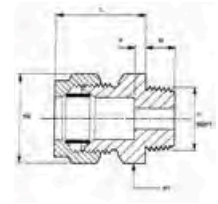

Male Stud Coupling BSPT-Imperial

### MALE STUD COUPLING BSPT-IMPERIAL

Part No	Tube OD.	T BSPT Male Thread	M Stud Length	L Length	H1 Hex A/F	H2 Hex A/F	P Abutment
7060	1/8	1/8	0.375	0.625	0.445	0.445	0.156
7060/3	1/8	1/4	0.531	0.656	0.601	0.445	0.187
7061	3/16	1/8	0.375	0.625	0.445	0.445	0.156
7061/3	3/16	1/4	0.531	0.656	0.601	0.445	0.187
7063/1	1/4	1/8	0.375	0.718	0.525	0.601	0.156
7063	1/4	1/4	0.531	0.718	0.525	0.601	0.156
7063/8	1/4	3/8	0.531	0.718	0.71	0.601	0.218
7063/11	1/4	1/2	0.687	0.781	0.92	0.601	0.218
7065/1	5/16	1/8	0.375	0.718	0.525	0.601	0.156
7065	5/16	1/4	0.531	0.718	0.525	0.601	0.156
7065/8	5/16	3/8	0.531	0.781	0.71	0.601	0.218
7065/11	5/16	1/2	0.687	0.781	0.92	0.601	0.218
7068/1	3/8	1/8	0.375	0.843	0.71	0.82	0.187
7068/3	3/8	1/4	0.531	0.843	0.71	0.82	0.187
7068	3/8	3/8	0.531	0.843	0.71	0.82	0.187
7068/11	3/8	1/2	0.687	0.843	0.92	0.82	0.187
7071/3	1/2	1/4	0.531	0.906	0.92	0.92	0.125
7071/8	1/2	3/8	0.531	0.906	0.92	0.92	0.125
7071	1/2	1/2	0.687	0.906	0.92	0.92	0.125
7073/11	5/8	1/2	0.687	1.062	1.1	1.2	0.187
7074/11	3/4	1/2	0.687	1.093	1.2	1.39	0.187
7074	3/4	3/4	0.687	1.093	1.2	1.39	0.187

### FEATURES & BENEFITS

- Inline Configuration with a Metric Parallel Male Stud Thread
- Enables tube connection to a mating Metric Parallel BS3643 Female threaded port

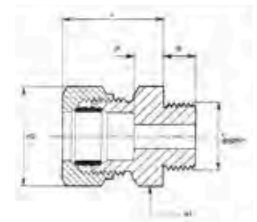

Male Stud Coupling-Metric Parallel

### MALE STUD COUPLING-METRIC PARALLEL

Part No	Tube OD.	T Metric Male Thread	M Stud Length	L Length	H1 Hex A/F	H2 Hex A/F	P Abutment
MCI10/14M15	10	M 14 x 1.5	8	25.5	17	19	10.5

Every effort has been made to ensure that the information contained in this publication is accurate at the time of publishing. Wade assumes no responsibility or liability for typographical errors or omissions or for any misinterpretation of the information within the publication and reserves the right to change without notice.

# Compression Fittings

## TUBE – MALE – STRAIGHT

### FEATURES & BENEFITS

- In-line configuration with a BSP Taper male stud thread
- Enables tube connection to a mating BSP Taper or BSP Parallel BS2I female threaded port



Male Stud Coupling BSPT-Metric

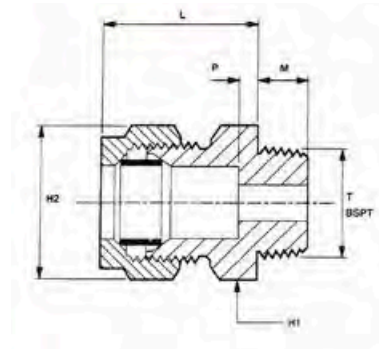

### MALE STUD COUPLING BSPT-METRIC

Part No	Tube OD.	T BSPT Male Thread	M Stud Length	L Length	H1 Hex A/F	H2 Hex A/F	P Abutment
MCI04/083	4	1/8	8.5	18.75	11	10	11
MCI04/163	4	1/4	12.5	19.75	14	10	14
MCI05/083	5	1/8	8.5	20.75	11	12	11
MCI05/163	5	1/4	12.5	21.75	14	12	14
MCI06/083	6	1/8	8.5	20.25	11	12	11
MCI06/163	6	1/4	12.5	21.25	14	12	14
MCI06/243	6	3/8	13	21.5	19	12	14.5
MCI08/083	8	1/8	8.5	22.75	13	14	12
MCI08/163	8	1/4	12.5	22.75	14	14	14
MCI08/243	8	3/8	13	23	19	14	14.5
MCI08/323	8	1/2	17	24	22	14	9
MCI10/083	10	1/8	8.5	23.75	17	19	13
MCI10/163	10	1/4	12.5	23.75	17	19	15
MCI10/243	10	3/8	13	24	19	19	15.5
MCI10/323	10	1/2	17	25.5	22	19	19
MCI12/163	12	1/4	12.5	24.75	19	22	15.5
MCI12/243	12	3/8	13	24.5	19	22	15.5
MCI12/323	12	1/2	17	26	22	22	19
MCI15/243	15	3/8	13	32	22	24	18
MCI15/323	15	1/2	17	33.5	24	24	21.5
MCI16/243	16	3/8	13	32.5	24	27	19
MCI16/323	16	1/2	17	33	24	27	21.5
MCI22/483	22	3/4	18	36.5	32	36	36
MCI25/483	25	3/4	18	36.5	36	41	36

Every effort has been made to ensure that the information contained in this publication is accurate at the time of publishing. Wade assumes no responsibility or liability for typographical errors or omissions or for any misinterpretation of the information within the publication and reserves the right to change without notice.

# Compression Fittings

## TUBE – MALE – STRAIGHT

### FEATURES & BENEFITS

- In-line configuration with a BSP parallel male stud thread
- Enables tube connection to a mating BSP parallel BS2779 female threaded port



Male Stud Coupling BSP Parallel-Imperial

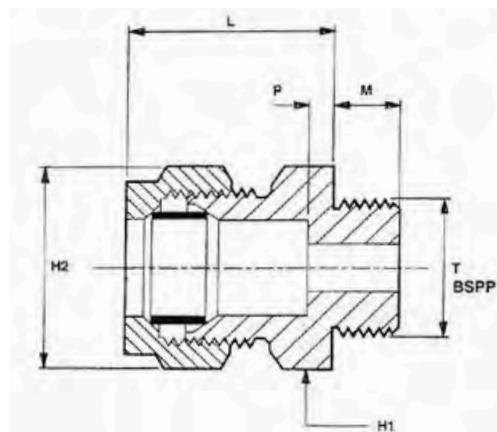

### MALE STUD COUPLING BSP PARALLEL-IMPERIAL

Part No	Tube OD.	T BSPP Male Thread	M Stud Length	L Length	H1 Hex A/F	H2 Hex A/F	P Abutment
1060	1/8	1/8	0.312	0.625	0.445	0.445	0.156
4060/3	1/8	1/4	0.343	0.656	0.71	0.445	0.187
1061	3/16	1/8	0.312	0.625	0.445	0.445	0.156
4061/3	3/16	1/4	0.343	0.656	0.71	0.445	0.187
4061/8	3/16	3/8	0.375	0.718	0.82	0.445	0.25
4063/1	1/4	1/8	0.312	0.718	0.525	0.601	0.156
1063	1/4	1/4	0.343	0.718	0.71	0.601	0.156
4063/8	1/4	3/8	0.375	0.781	0.82	0.601	0.218
4063/11	1/4	1/2	0.437	0.781	0.92	0.601	0.218
4065/1	5/16	1/8	0.312	0.718	0.525	0.601	0.156
1065	5/16	1/4	0.343	0.718	0.71	0.601	0.156
4065/8	5/16	3/8	0.375	0.781	0.82	0.601	0.218
4065/11	5/16	1/2	0.437	0.781	0.92	0.601	0.218
4068/3	3/8	1/4	0.343	0.843	0.71	0.82	0.187
1068	3/8	3/8	0.375	0.843	0.82	0.82	0.187
4068/11	3/8	1/2	0.437	0.843	0.92	0.82	0.187
4071/3	1/2	1/4	0.343	0.906	0.92	0.92	0.125
4071/8	1/2	3/8	0.375	0.906	0.92	0.92	0.125
1071	1/2	1/2	0.437	0.906	0.92	0.92	0.125
4071/14	1/2	3/4	0.5	0.906	1.2	0.92	0.125
4073/11	5/8	1/2	0.437	1	1.1	1.2	0.125
4074/11	3/4	1/2	0.437	1.093	1.2	1.39	0.187
1074	3/4	3/4	0.5	1.093	1.3	1.39	0.187
1076	7/8	3/4	0.5	1.125	1.39	1.48	0.187

Every effort has been made to ensure that the information contained in this publication is accurate at the time of publishing. Wade assumes no responsibility or liability for typographical errors or omissions or for any misinterpretation of the information within the publication and reserves the right to change without notice.



# Compression Fittings

## TUBE – MALE – STRAIGHT

### FEATURES & BENEFITS

- In-line configuration with a BSP parallel male stud thread
- Enables tube connection to a mating BSP parallel BS2779 female threaded port



Male Stud Coupling BSP Parallel-Metric

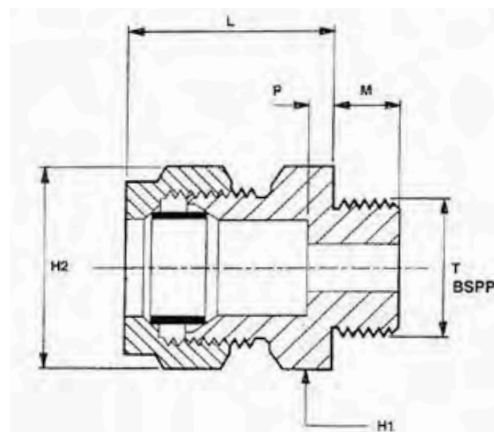

### MALE STUD COUPLING BSP PARALLEL-METRIC

Part No	Tube OD.	T BSPP Male Thread	M Stud Length	L Length	H1 Hex A/F	H2 Hex A/F	P Abutment
MCI04/161	4	1/4	10.5	22	19	10	9.5
MCI06/081	6	1/8	7	22	14	12	8.5
MCI06/161	6	1/4	10.5	23	19	12	9.5
MCI06/241	6	3/8	11	24.5	22	12	11
MCI08/081	8	1/8	7	23.5	14	14	8.5
MCI08/161	8	1/4	10.5	24.5	19	14	9.5
MCI08/241	8	3/8	11	26	22	14	11
MCI10/161	10	1/4	10.5	25.5	19	19	10.5
MCI10/241	10	3/8	11	27	22	19	12
MCI10/321	10	1/2	14.5	28.5	27	19	13.5
MCI12/161	12	1/4	10.5	26	19	22	10.5
MCI12/241	12	3/8	11	27.5	22	22	12
MCI12/321	12	1/2	14.5	29	27	22	13.5
MCI15/241	15	3/8	11	33	22	24	13.5
MCI15/321	15	1/2	14.5	35.5	27	24	15
MCI16/321	16	1/2	14.5	35	27	27	15
MCI18/321	18	1/2	14.5	36.5	27	30	15
MCI20/481	20	3/4	16	37	32	32	16.5
MCI22/481	22	3/4	16	39	32	36	16.5
MCI22/641	22	1	18.5	39	41	36	16.5
MCI25/481	25	3/4	16	39	36	41	16.5
MCI25/641	25	1	18.5	39	41	41	16.5
MCI28/641	28	1	18.5	40.2	41	41	14.5

Every effort has been made to ensure that the information contained in this publication is accurate at the time of publishing. Wade assumes no responsibility or liability for typographical errors or omissions or for any misinterpretation of the information within the publication and reserves the right to change without notice.

# Compression Fittings

## TUBE – MALE – BRANCH TEE

### FEATURES & BENEFITS

- 'T' configuration, in-line tube to tube compression with BSP taper male stud thread on the branch
- Enables in-line connection of 2 tubes of the same outside diameter to a mating BSP taper or BSP parallel BS21 female threaded port



Male Branch Tee BSPT-Imperial



Male Branch Tee BSPT-Metric

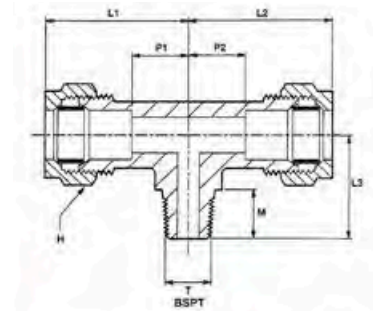

### MALE BRANCH TEE BSPT-IMPERIAL

Part No	Tube OD.	Tube OD.	T BSPT Male Thread	L1 & L2 Length	L3 Length	H Hex A/F	P1 & P2 Abutment	M Stud Length
9063/1B	1/4	1/4	1/8	0.812	0.75	0.601	0.375	0.375
9063B	1/4	1/4	1/4	1	0.937	0.601	0.281	0.531
9068/3B	3/8	3/8	1/4	1.093	0.812	0.82	0.375	0.531
9068B	3/8	3/8	3/8	1.093	1.031	0.82	0.562	0.531

### MALE BRANCH TEE BSPT-METRIC

Part No	Tube OD.	Tube OD.	T BSPT Male Thread	L1 & L2 Length	L3 Length	H Hex A/F	P1 & P2 Abutment	M Stud Length
MT106/083	6	6	1/8	24	17	12	10.5	7
MT106/163	6	6	1/4	24	20.5	12	10.5	10.5
MT108/163	8	8	1/4	25.5	20.5	14	10.5	10.5

Every effort has been made to ensure that the information contained in this publication is accurate at the time of publishing. Wade assumes no responsibility or liability for typographical errors or omissions or for any misinterpretation of the information within the publication and reserves the right to change without notice.

# Compression Fittings

## TUBE – MALE – RUN TEE

### FEATURES & BENEFITS

- 'T' configuration, 90° tube to tube compression with BSP taper male stud thread on the run
- Enables 90° connection of 2 tubes of the same outside diameter to a mating BSP taper or BSP parallel BS2I female threaded port



Male Run Tee BSPT-Imperial



Male Run Tee BSPT-Metric

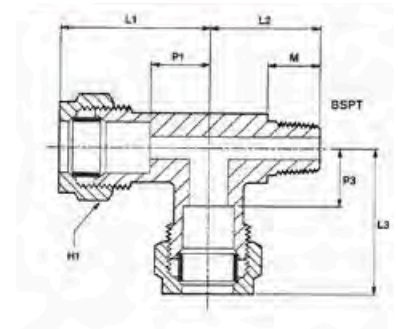

### MALE RUN TEE BSPT-IMPERIAL

Part No	Tube OD.	T BSPT Male Thread	Tube OD.	L1 & L3 Length	L2 Length	H Hex A/F	P1 & P2 Abutment	M Stud Length
9061E	3/16	1/8	3/16	0.781	0.625	0.445	0.312	0.375
9063E	1/4	1/4	1/4	1	0.937	0.601	0.281	0.531
9068/3E	3/8	1/4	3/8	1.093	0.812	0.82	0.375	0.531

### MALE RUN TEE BSPT-METRIC

Part No	Tube OD.	T BSPT Male Thread	Tube OD.	L1 & L3 Length	L2 Length	H Hex A/F	P1 & P2 Abutment	M Stud Length
MT083/106	6	1/8	6	24	17	12	10.5	7
MT163/106	6	1/4	6	24	20.5	12	10.5	10.5
MT163/108	8	1/4	8	25.5	20.5	14	10.5	10.5

Every effort has been made to ensure that the information contained in this publication is accurate at the time of publishing. Wade assumes no responsibility or liability for typographical errors or omissions or for any misinterpretation of the information within the publication and reserves the right to change without notice.

# Compression Fittings

## TUBE – FEMALE – ELBOW

### FEATURES & BENEFITS

- 90° Elbow configuration with a BSP parallel female stud thread
- Enables tube connection to a mating BSP parallel BS2779 male thread



Female Stud Elbow BSP Parallel-Imperial



Female Stud Elbow BSP Parallel-Metric

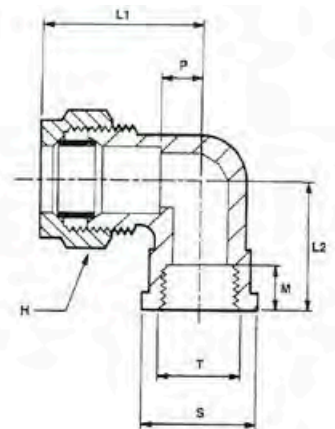

### FEMALE STUD ELBOW BSP PARALLEL-IMPERIAL

Part No	Tube OD.	T BSP Female Thread	M Stud Length	L1 Length	L2 Length	H Hex A/F	P Abutment	S Diameter
1983	1/4	1/4	0.312	1.062	0.687	0.601	0.5	0.75
1985	5/16	1/4	0.312	1.062	0.687	0.601	0.5	0.75

### FEMALE STUD ELBOW BSP PARALLEL-METRIC

Part No	Tube OD.	T BSP Female Thread	M Stud Length	L1 Length	L2 Length	H Hex A/F	P Abutment	S Diameter
ME106/082	6	1/8	9	27	25.7	12	13.5	14
ME106/162	6	1/4	13.5	27	30.2	12	13.5	18
ME108/082	8	1/8	9	28.5	25.7	14	13.5	14
ME108/162	8	1/4	13.5	28.5	30.2	14	13.5	18
ME110/162	10	1/4	13.5	31.5	34.2	19	16.5	18
ME110/242	10	3/8	14	31.5	34.7	19	16.5	22
ME112/322	12	1/2	18	34	39	22	18.5	26
ME115/322	15	1/2	18	40.5	39	24	20	26
ME116/322	16	1/2	18	39.5	39	27	20	26

Every effort has been made to ensure that the information contained in this publication is accurate at the time of publishing. Wade assumes no responsibility or liability for typographical errors or omissions or for any misinterpretation of the information within the publication and reserves the right to change without notice.

# Compression Fittings

## TUBE – FEMALE – STRAIGHT

### FEATURES & BENEFITS

- In-line configuration with an API female stud thread
- Enables tube connection to a mating API or NPT male thread



Female Stud Coupling API-Imperial

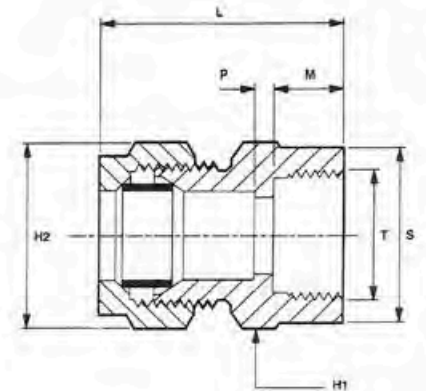

### FEMALE STUD COUPLING API-IMPERIAL

Part No	Tube OD.	T API Female Thread	M Stud Length	L Length	H1 Hex A/F	H2 Hex A/F	P Abutment	S Diameter
1080API	1/8	1/8	0.375	0.906	0.525	0.445	0.062	0.525
1081API	3/16	1/8	0.375	0.906	0.525	0.445	0.062	0.525
4081/3API	3/16	1/4	0.562	1.125	0.71	0.445	0.093	0.71
4083/1API	1/4	1/8	0.375	1.031	0.525	0.601	0.093	0.525
1083API	1/4	1/4	0.562	1.25	0.71	0.601	0.125	0.71
4083/11API	1/4	1/2	0.75	1.437	1.01	0.601	0.125	1.01
1088API	3/8	3/8	0.562	1.343	0.92	0.82	0.125	0.92
4088/11API	3/8	1/2	0.75	1.531	1.01	0.82	0.125	1.01
1091API	1/2	1/2	0.75	1.656	1.01	0.92	0.125	1.01

Every effort has been made to ensure that the information contained in this publication is accurate at the time of publishing. Wade assumes no responsibility or liability for typographical errors or omissions or for any misinterpretation of the information within the publication and reserves the right to change without notice.



# Compression Fittings

## TUBE – FEMALE – STRAIGHT

### FEATURES & BENEFITS

- In-line Configuration with a BSP taper female stud thread
- Enables tube connection to a mating BSP taper male thread



Female Stud Coupling BSPT-Imperial



Female Stud Coupling BSPT-Metric

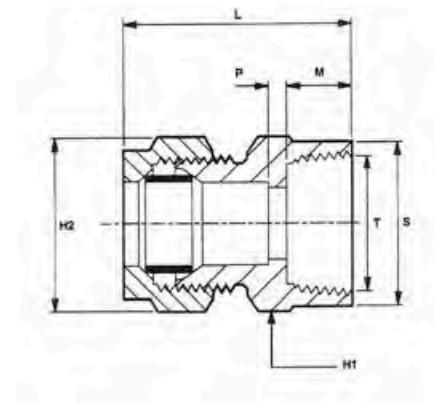

### FEMALE STUD COUPLING BSPT-IMPERIAL

Part No	Tube OD.	T BSPT Female Thread	M Stud Length	L Length	H1 Hex A/F	H2 Hex A/F	P Abutment	S Diameter
7083/1	1/4	1/8	0.375	1.031	0.525	0.601	0.093	0.525
7083	1/4	1/4	0.531	1.218	0.71	0.601	0.125	0.71
7083/8	1/4	3/8	0.531	1.218	0.92	0.601	0.125	0.92
7083/11	1/4	1/2	0.687	1.375	1.01	0.601	0.125	1.01
7085	5/16	1/4	0.531	1.218	0.71	0.601	0.125	0.71
7085/8	5/16	3/8	0.531	1.218	0.92	0.601	0.125	0.92
7088/3	3/8	1/4	0.531	1.312	0.71	0.82	0.125	0.71
7088	3/8	3/8	0.531	1.312	0.92	0.82	0.125	0.92
7088/11	3/8	1/2	0.687	1.468	1.01	0.82	0.125	1.01
7091	1/2	1/2	0.687	1.593	1.01	0.92	0.125	1.01

### FEMALE STUD COUPLING BSPT-METRIC

Part No	Tube OD.	T BSPT Female Thread	M Stud Length	L Length	H1 Hex A/F	H2 Hex A/F	P Abutment	S Diameter
MC106/164	6	1/4	13.5	46.5	22	12	6	Not applicable
MC108/164	8	1/4	13.5	48	20	14	6	Not applicable

Every effort has been made to ensure that the information contained in this publication is accurate at the time of publishing. Wade assumes no responsibility or liability for typographical errors or omissions or for any misinterpretation of the information within the publication and reserves the right to change without notice.

# Compression Fittings

## TUBE – FEMALE – STRAIGHT

### FEATURES & BENEFITS

- In-line configuration with a BSP parallel female stud thread
- Enables tube connection to a mating BSP parallel male thread on a pressure gauge
- Designed with a BSP parallel female thread to enable tube connection with a pressure gauge
- The internal form at the back of this thread is dimensioned to house the external male BSP parallel connection thread of the pressure gauge



Female Pressure Gauge Connector BSP Parallel-Imperial



Female Pressure Gauge Connector BSP Parallel-Metric

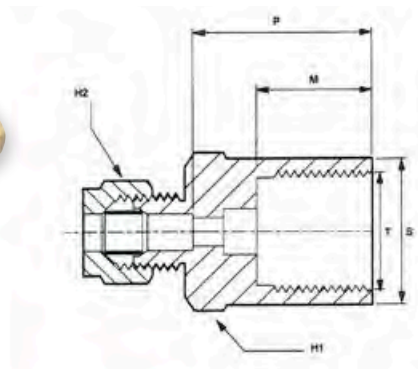

### FEMALE PRESSURE GAUGE CONNECTOR BSP PARALLEL-IMPERIAL

Part No	Tube OD.	T BSPP Female Thread	M Stud Length	H1 Hex A/F	H2 Hex A/F	P Abutment	S Diameter
1083A	1/4	1/4	0.437	0.71	0.601	0.781	0.7
4083/8A	1/4	3/8	0.5	0.92	0.601	0.875	0.9
4083/11A	1/4	1/2	0.75	1.01	0.601	1.125	0.982
1088A	3/8	3/8	0.5	0.92	0.82	0.718	0.9
4088/11A	3/8	1/2	0.75	1.01	0.82	0.968	0.982

### FEMALE PRESSURE GAUGE CONNECTOR BSP PARALLEL-METRIC

Part No	Tube OD.	T BSPP Female Thread	M Stud Length	H1 Hex A/F	H2 Hex A/F	P Abutment	S Diameter
MGA104/162	4	1/4	11	19	10	22	Not applicable
MGA106/082	6	1/8	7.5	14	12	16.5	Not applicable
MGA106/162	6	1/4	11	19	12	22	Not applicable
MGA106/242	6	3/8	11.5	22	12	22.5	Not applicable
MGA106/322	6	1/2	15.5	27	12	25.5	Not applicable
MGA110/242	10	3/8	11.5	22	19	21	Not applicable

Every effort has been made to ensure that the information contained in this publication is accurate at the time of publishing. Wade assumes no responsibility or liability for typographical errors or omissions or for any misinterpretation of the information within the publication and reserves the right to change without notice.

# Compression Fittings

## TUBE – FEMALE – STRAIGHT

### FEATURES & BENEFITS

- In-line configuration with a BSP parallel female stud thread
- Enables tube connection to a mating BSP Parallel male thread



Female Stud Coupling BSPP-Imperial

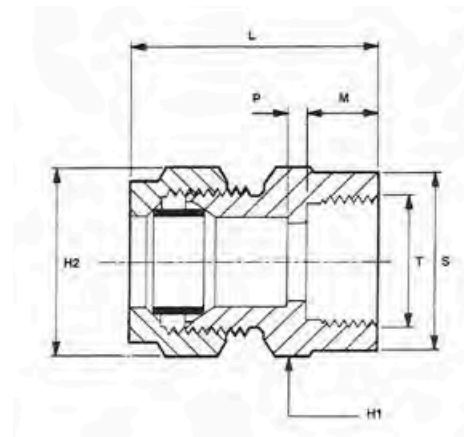

### FEMALE STUD COUPLING BSP PARALLEL - IMPERIAL

Part No	Tube OD.	T BSPP Female Thread	M Stud Length	L Length	H1 Hex A/F	H2 Hex A/F	P Abutment	S Diameter
1080	1/8	1/8	0.25	0.812	0.525	0.445	0.093	0.525
4080/3	1/8	1/4	0.25	0.843	0.71	0.445	0.125	0.71
1081	3/16	1/8	0.25	0.812	0.525	0.445	0.093	0.525
4081/3	3/16	1/4	0.25	0.843	0.71	0.445	0.125	0.71
4081/8	3/16	3/8	0.312	0.906	0.82	0.445	0.125	0.82
4083/1	1/4	1/8	0.25	0.906	0.525	0.601	0.093	0.525
1083	1/4	1/4	0.25	0.937	0.71	0.601	0.125	0.71
4083/8	1/4	3/8	0.312	1	0.82	0.601	0.125	0.82
4083/11	1/4	1/2	0.375	1.062	1.01	0.601	0.125	1.01
4085/1	5/16	1/8	0.25	0.906	0.525	0.601	0.093	0.525
1085	5/16	1/4	0.25	0.937	0.71	0.601	0.125	0.71
4085/11	5/16	1/2	0.375	1.062	1.01	0.601	0.125	1.01
4088/1	3/8	1/8	0.25	1	0.71	0.82	0.093	0.71
4088/3	3/8	1/4	0.25	1.031	0.71	0.82	0.125	0.71
1088	3/8	3/8	0.312	1.093	0.82	0.82	0.125	0.82
4088/11	3/8	1/2	0.375	1.156	1.01	0.82	0.125	1.01
4091/8	1/2	3/8	0.312	1.218	0.92	0.92	0.125	0.92
1091	1/2	1/2	0.375	1.281	1.01	0.92	0.125	1.01
1097	1	1	0.75	1.875	1.67	1.67	0.125	1.67

Every effort has been made to ensure that the information contained in this publication is accurate at the time of publishing. Wade assumes no responsibility or liability for typographical errors or omissions or for any misinterpretation of the information within the publication and reserves the right to change without notice.

# Compression Fittings

## TUBE – FEMALE – STRAIGHT

### FEATURES & BENEFITS

- In-line configuration with a BSP parallel female stud thread
- Enables tube connection to a mating BSP Parallel male thread



Female Stud Coupling BSPP-Metric

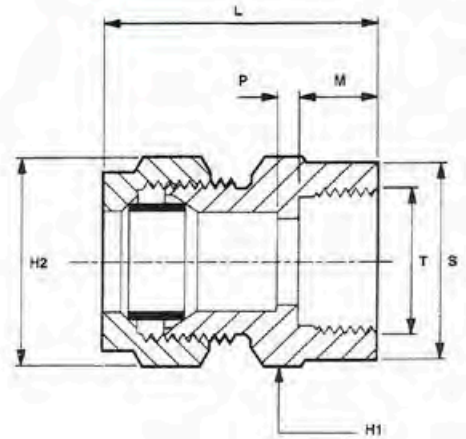

### FEMALE STUD COUPLING BSP PARALLEL - METRIC

Part No	Tube OD.	T BSPP Female Thread	M Stud Length	L Length	H1 Hex A/F	H2 Hex A/F	P Abutment	S Diameter
MCI04/082	4	1/8	9	26	14	10	5	Not applicable
MCI04/162	4	1/4	13.5	31.5	19	10	6	Not applicable
MCI05/082	5	1/8	9	27	14	12	5	Not applicable
MCI06/082	6	1/8	9	27.5	14	12	5	Not applicable
MCI06/162	6	1/4	13.5	33	19	12	6	Not applicable
MCI08/082	8	1/8	9	29	14	14	5	Not applicable
MCI08/162	8	1/4	13.5	34.5	19	14	6	Not applicable
MCI08/242	8	3/8	14	35	22	14	6	Not applicable
MCI10/162	10	1/4	13.5	35.5	19	19	7	Not applicable
MCI10/242	10	3/8	14	36	22	19	7	Not applicable
MCI10/322	10	1/2	18	40.5	27	19	7.5	Not applicable
MCI12/162	12	1/4	13.5	36	19	22	7	Not applicable
MCI12/242	12	3/8	14	36.5	22	22	7	Not applicable
MCI12/322	12	1/2	18	41	27	22	7.5	Not applicable
MCI15/242	15	3/8	14	43	22	24	8.5	Not applicable
MCI15/322	15	1/2	18	47.5	27	24	9	Not applicable
MCI16/322	16	1/2	18	46.5	27	27	9	Not applicable
MCI22/482	22	3/4	19.5	51.5	32	36	9.5	Not applicable

Every effort has been made to ensure that the information contained in this publication is accurate at the time of publishing. Wade assumes no responsibility or liability for typographical errors or omissions or for any misinterpretation of the information within the publication and reserves the right to change without notice.

# Compression Fittings

## TUBE – FEMALE – TEE

### FEATURES & BENEFITS

- ‘T’ configuration, in-line tube to tube compression with BSP parallel female Stud thread on the branch
- Enables in-line connection of 2 tubes of the same outside diameter to a mating BSP parallel BS2779 male thread



Female Branch Tee BSP Parallel-Imperial

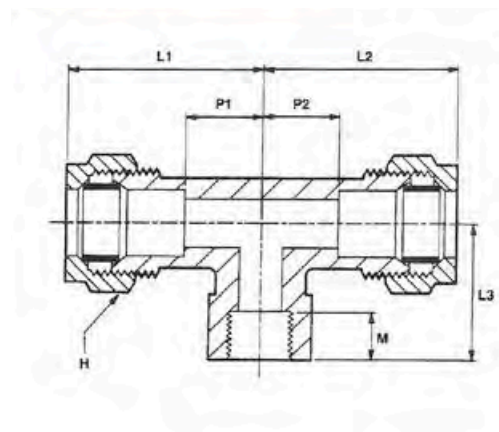

### FEMALE BRANCH TEE BSP PARALLEL-IMPERIAL

Part No	Tube OD.	Tube OD.	T BSPP Female Thread	L1 & L2 Length	L3 Length	H Hex A/F	P1 & P2 Abutment	M Stud Length
3083B	1/4	1/4	1/4	1.187	0.875	0.601	0.5	0.437

Every effort has been made to ensure that the information contained in this publication is accurate at the time of publishing. Wade assumes no responsibility or liability for typographical errors or omissions or for any misinterpretation of the information within the publication and reserves the right to change without notice.



# Compression Fittings

## PLUG COCKS & NEEDLE VALVES

### FEATURES & BENEFITS

- In-line configuration
- Enables connection of 2 tubes of the same outside diameter
- Lever handle and 1/4 turn operation.
- Incorporates an internal plug which is drilled across its axis, allowing flow only when the drilled hole is in line with the inlet and outlet
- Designed for low pressure hydraulic and pneumatic applications with a maximum working pressure of 30 PSI / 2 Bar



*Plug Cock-Imperial*

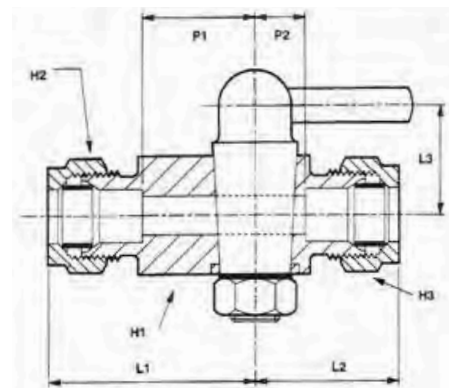

### PLUG COCK-IMPERIAL

Part No	Tube OD.	Tube OD.	L1 Length	L2 Length	L3 Length	H1 Hex A/F	H2 Hex A/F	H3 Hex A/F	P1 Abutment	P2 Abutment
3003	1/4	1/4	1.25	0.875	0.625	0.525	0.601	0.601	0.687	0.312
3005	5/16	5/16	1.25	0.875	0.625	0.525	0.601	0.601	0.687	0.312

Every effort has been made to ensure that the information contained in this publication is accurate at the time of publishing. Wade assumes no responsibility or liability for typographical errors or omissions or for any misinterpretation of the information within the publication and reserves the right to change without notice.

# Compression Fittings

## PLUG COCKS & NEEDLE VALVES

### FEATURES & BENEFITS

- In-line configuration
- Enables connection of 2 tubes of the same outside diameter
- A simple needle valve of brass construction (with the exception of the handle and nitrile 'O' rings)
- The design of the valve spindle enables control of the flow medium
- The design incorporates a 'foot plate' with 2 countersunk holes allowing the valve to be mounted securely against a floor, wall or panel
- Designed for low pressure hydraulic and pneumatic applications
- Maximum working pressure: 100 PSI / 6.8 Bar
- Working temperature range: -40° C to +135°C

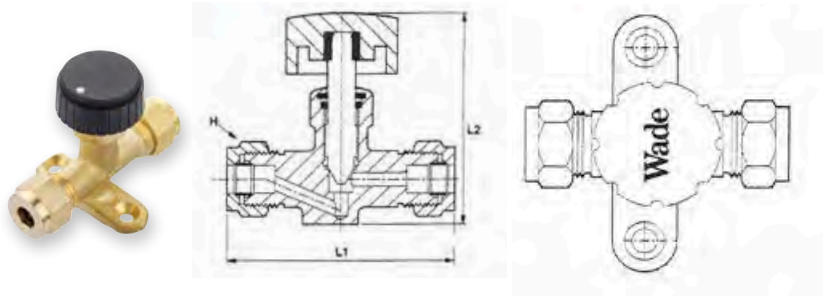

Needle Valve-Foot Mounted-Tube-Tube

### NEEDLE VALVE-FOOT MOUNTED-TUBE-TUBE-IMPERIAL

Part No	Tube OD.	Tube OD.	L1 Length	L2 Length	H Hex A/F
WVA4/B16	1/4	1/4	2.25	1.562	0.601
WVA4/B20	5/16	5/16	2.25	1.562	0.601

### FEATURES & BENEFITS

- In-line configuration
- Enables connection of copper, nylon tube etc. to 3/8" (10mm) inside diameter LPG rubber hose
- A simple needle valve of brass construction (with the exception of the handle and nitrile 'O' rings)
- The design of the valve spindle enables control of the flow medium
- The design incorporates a 'foot plate' with 2 countersunk holes allowing the valve to be mounted securely against a floor, wall or panel
- Designed for low pressure hydraulic and pneumatic applications
- Maximum working pressure: 100 PSI / 6.8 Bar
- Working temperature range: -40° C to +135°C

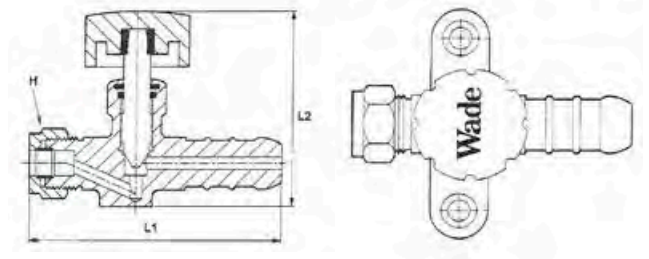

Needle Valve-Foot Mounted-Tube-Hose

### NEEDLE VALVE-FOOT MOUNTED-TUBE-HOSE-IMPERIAL

Part No	Tube OD.	Hose ID.	L1 Length	L2 Length	H Hex A/F
WVA4/B/16/F1	1/4	3/8	2.468	1.562	0.601

Every effort has been made to ensure that the information contained in this publication is accurate at the time of publishing. Wade assumes no responsibility or liability for typographical errors or omissions or for any misinterpretation of the information within the publication and reserves the right to change without notice.

# Compression Fittings

## PLUG COCKS & NEEDLE VALVES

### FEATURES & BENEFITS

- In-line configuration
- Enables connection of 2 tubes of the same outside diameter
- A simple needle valve of brass construction (with the exception of the handle and nitrile 'O' rings)
- The design of the valve spindle enables control of the flow medium
- Designed for low and medium pressure hydraulic and pneumatic applications
- Maximum working pressure:  
Hydraulic applications: 3,000 PSI / 200 Bar  
Pneumatic applications: 1,000 PSI / 67 Bar
- Working temperature range: -40° C to +135° C

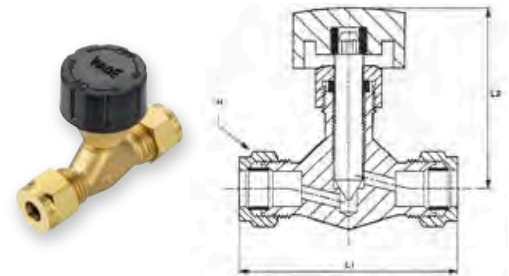

*Straight Needle Valve Tube-Tube-Imperial*

### STRAIGHT NEEDLE VALVE TUBE-TUBE-IMPERIAL

Part No	Spindle Type	Tube OD.	L1 Length	L2 Length	H Hex A/F
WVA1/SS/12	Stainless Steel	3/16	1.687	1.25	0.445
WVA1/B/16	Brass	1/4	2.125	1.7	0.601
WVA1/B/20	Brass	5/16	2.125	1.7	0.601

### FEATURES & BENEFITS

- In-line configuration
- Enables connection of 2 tubes of the same outside diameter
- A simple needle valve of brass construction (with the exception of the handle and nitrile 'O' rings)
- The design of the valve spindle enables control of the flow medium
- The design incorporates a simple locknut mechanism enabling the valve to be secured and locked in place through a control panel.
- Designed for low and medium pressure hydraulic and pneumatic applications
- Maximum working pressure:  
Hydraulic applications: 3,000 PSI / 200 bar  
Pneumatic applications: 1,000 PSI / 67 bar
- Working temperature range: - 40° C to + 135° C

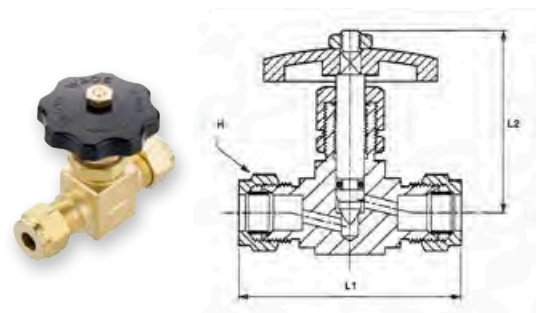

*Straight Needle Valve Panel Mounting Tube- Tube-Imperial*

### STRAIGHT NEEDLE VALVE PANEL MOUNTING TUBE-TUBE-IMPERIAL

Part No	Spindle Type	Tube OD.	L1 Length	L2 Length	H Hex A/F	Max Bulkhead	Bulkhead Hole Dia
WVA2/B/16	Brass	1/4	2.125	1.7	0.601	1/8	0.531 (17/32")
WVA2/B/20	Brass	5/16	2.125	1.7	0.601	1/8	0.531 (17/32")

Every effort has been made to ensure that the information contained in this publication is accurate at the time of publishing. Wade assumes no responsibility or liability for typographical errors or omissions or for any misinterpretation of the information within the publication and reserves the right to change without notice.

# Compression Fittings

## PLUG COCKS & NEEDLE VALVES

### FEATURES & BENEFITS

- 90° configuration
- Enables connection of 2 tubes of the same outside diameter
- A simple needle valve of brass construction (with the exception of the handle and nitrile 'O' rings)
- The design of the valve spindle enables control of the flow medium
- The design incorporates a simple locknut mechanism enabling the valve to be secured and locked in place through a control panel.
- Designed for low and medium pressure hydraulic and pneumatic applications
- Maximum working pressure:  
Hydraulic applications: 3,000 PSI / 200 Bar  
Pneumatic applications: 1,000 PSI / 67 Bar
- Working temperature range: -40° C to +135° C



Angle Needle Valve Panel Mounting Tube-  
Tube-Imperial

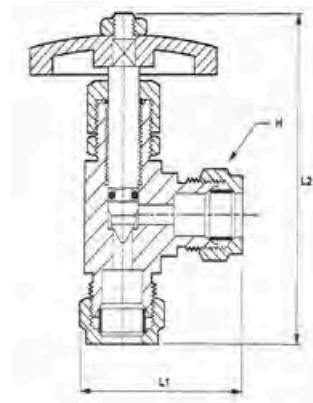

### ANGLE NEEDLE VALVE PANEL MOUNTING TUBE-TUBE-IMPERIAL

Part No	Spindle Type	Tube OD.	L1 Length	L2 Length	H Hex A/F	Max Bulkhead	Bulkhead Hole Dia
WVA3/B/16	Brass	1/4	1.2	2.75	0.601	3/16	0.562 (9/16")
WVA3/B/20	Brass	5/16	1.2	2.75	0.601	3/16	0.562 (9/16")

Every effort has been made to ensure that the information contained in this publication is accurate at the time of publishing. Wade assumes no responsibility or liability for typographical errors or omissions or for any misinterpretation of the information within the publication and reserves the right to change without notice.

# Compression Fittings

## ADAPTORS

### FEATURES & BENEFITS

- A range of screwed plugs including; BSP parallel, BSP taper and API thread options
- Providing a blanking solution, these plugs are designed to be screwed into a mating female threaded port to blank off the aperture



Screwed Plug-API-Imperial



Screwed Plug-BSPT-Imperial

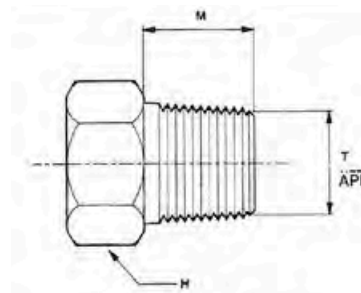

### SCREWED PLUG-API-IMPERIAL

Part No	T Stud Size	H Hex A/F	M Stud Length
587/1	1/8	0.437	0.437
587/2	1/4	0.562	0.5
587/3	3/8	0.687	0.625
587/4	1/2	0.875	0.718

### SCREWED PLUG-BSPT-IMPERIAL

Part No	T Stud Size	H Hex A/F	M Stud Length
587/9	1/8	0.445	0.437
587/10	1/4	0.601	0.5
587/11	3/8	0.82	0.625
587/12	1/2	0.92	0.718



Screwed Plug-BSP Parallel-Imperial

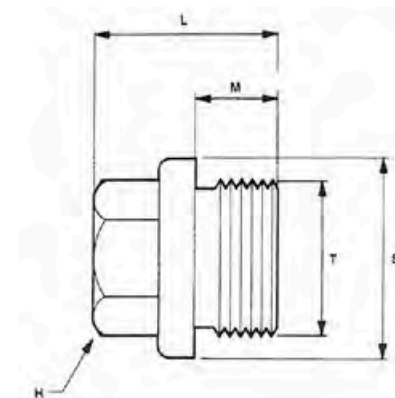

### SCREWED PLUG-BSP PARALLEL-IMPERIAL

Part No	T Stud Size	M Stud Length	L Length	H Hex A/F	S Diameter
884/1	1/8	0.25	0.531	0.445	0.671
884/2	1/4	0.25	0.593	0.525	0.812
884/3	3/8	0.312	0.703	0.6	0.968
884/4	1/2	0.343	0.781	0.71	1.14
884/6	3/4	0.375	0.89	0.92	1.421
884/8	1	0.406	1.015	1.1	1.671

Every effort has been made to ensure that the information contained in this publication is accurate at the time of publishing. Wade assumes no responsibility or liability for typographical errors or omissions or for any misinterpretation of the information within the publication and reserves the right to change without notice.



# Compression Fittings

## ADAPTORS

### FEATURES & BENEFITS

- A range of brass BSP taper male to male threaded adaptors
- Providing a jointing solution where 2 component parts with mating BSP taper or BSP parallel BS21 female threads need to be connected



Hexagon Nipple-BSPT

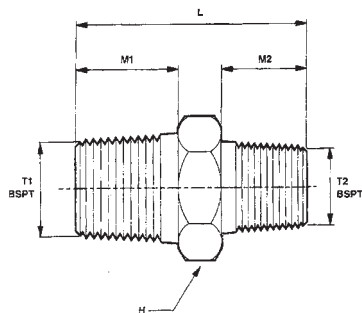

### FEATURES & BENEFITS

- A range of brass BSP taper male to BSP Parallel female threaded adaptors. When screwed onto a BSP parallel male stud thread they convert that end to BSP taper male
- Providing a jointing solution where one component part with a mating BSP parallel male BS2779 thread needs to be connected to another component part with a larger mating BSP taper or BSP parallel BS21 female thread



Male BSPT To Female BSPP Adaptor-Form A

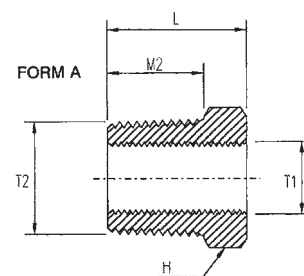

## HEXAGON NIPPLE-BSPT

Part No	T1 Stud	T2 Stud	M1 Length	M2 Length	Length	H Hex A/F
MA083/083	1/8	1/8	8.5	8.5	21	11
MA163/083	1/4	1/8	12.5	8.5	26	14
MA163/163	1/4	1/4	12.5	12.5	30	14
MA243/163	3/8	1/4	13	12.5	30.5	17
MA243/243	3/8	3/8	13	13	31	17
MA323/163	1/2	1/4	17	12.5	36	22
MA323/243	1/2	3/8	17	13	36.5	22
MA323/323	1/2	1/2	17	17	40.5	22
MA483/323	3/4	1/2	18	17	42.5	27
MA483/483	3/4	3/4	18	18	43.5	27

## MALE BSPT TO FEMALE BSPP ADAPTOR-FORM A

Part No	T1 Female BSPP	T2 Male BSPT	L Length	M2 Length	H Hex A/F
MRB082/163	1/8	1/4	17.5	12.5	14
MRB082/243	1/8	3/8	18.5	13	17
MRB162/243	1/4	3/8	18.5	13	17
MRB162/323	1/4	1/2	23.5	17	22
MRB242/323	3/8	1/2	23.5	17	22
MRB242/483	3/8	3/4	27	18	27
MRB322/483	1/2	3/4	27	18	27

Every effort has been made to ensure that the information contained in this publication is accurate at the time of publishing. Wade assumes no responsibility or liability for typographical errors or omissions or for any misinterpretation of the information within the publication and reserves the right to change without notice.

# Compression Fittings

## ADAPTORS

### FEATURES & BENEFITS

- A range of brass BSP parallel male to BSP parallel female threaded adaptors
- Providing a jointing solution where one component part with a mating BSP parallel BS2779 male thread needs to be connected to another component part with a mating BSP parallel BS2779 Female thread



Male BSP Parallel To Female BSP Parallel Adaptor

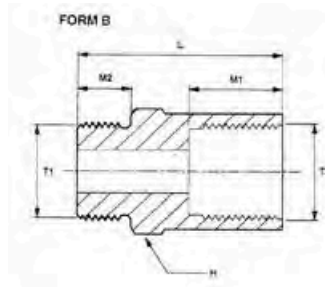
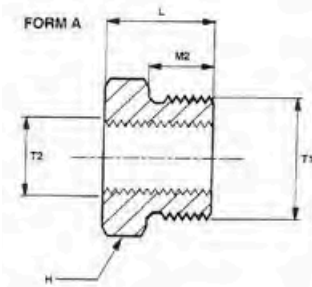

### FEATURES & BENEFITS

- A range of brass BSP parallel female to BSP parallel female threaded adaptors
- Providing a jointing solution where 2 component parts with mating BSP parallel BS2779 male threads need to be connected



Female To Female Adaptor-BSP Parallel

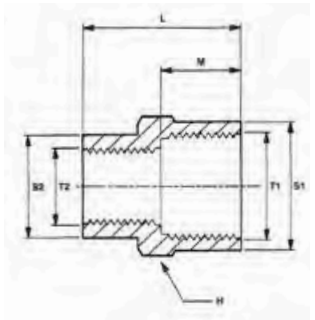

### MALE BSP PARALLEL TO FEMALE BSP PARALLEL ADAPTOR

Part No	T1 Male Stud	T2 Female Stud	L Length	M1 Length	M2 Length	H Hex A/F	Form
I21HEX	1/8	1/4	0.687	0.25	0.312	0.71	B
I23HEX	1/4	1/4	0.75	0.25	0.343	0.71	B
I24HEX	1/4	3/8	0.812	0.312	0.343	0.82	B
I25HEX	1/4	1/2	0.875	0.375	0.343	1.01	B
I30	1/4	1/8	0.531	N/A	0.312	0.6	A
I31	3/8	1/8	0.625	N/A	0.375	0.82	A
I32	3/8	1/4	0.625	N/A	0.375	0.82	A
I33	1/2	1/8	0.687	N/A	0.437	0.92	A
I34	1/2	1/4	0.687	N/A	0.437	0.92	A
I35	1/2	3/8	0.687	N/A	0.437	0.92	A

### FEMALE TO FEMALE ADAPTOR-BSP PARALLEL

Part No	T1 Female	T2 Female	L Length	M Length	S1 Diameter	S2 Diameter	H Hex A/F
I10	1/8	1/8	0.875	N/A	0.531	0.531	0.6
I11	1/4	1/8	0.875	0.437	0.656	0.531	0.71
I12	1/4	1/4	1	N/A	0.656	0.656	0.71
I13	3/8	1/8	0.937	0.5	0.781	0.531	0.82
I14	3/8	1/4	1	0.5	0.781	0.656	0.82
I15	3/8	3/8	1.125	N/A	0.781	0.781	0.82
I17	1/2	1/4	1.125	0.625	0.953	0.656	1.01
I18	1/2	3/8	1.187	0.625	0.953	0.75	1.01
I19	1/2	1/2	1.375	N/A	0.953	0.953	1.01

Every effort has been made to ensure that the information contained in this publication is accurate at the time of publishing. Wade assumes no responsibility or liability for typographical errors or omissions or for any misinterpretation of the information within the publication and reserves the right to change without notice.

# Compression Fittings

## ADAPTORS

### FEATURES & BENEFITS

- A range of brass BSP taper male standpipe adaptors
- Providing a jointing solution where a component with a standard compression end needs to be connected to another component part with a mating BSP taper or BSP parallel BS21 female thread
- The standpipe feature allows rotational adjustment enabling the standpipe stem to be jointed with a corresponding compression end, in any alignment within a 360° turning circle
- The stem feature of the standpipe enables the conversion of a corresponding compression end into a BSP taper male stud thread connection



Standpipe Adaptor  
BSPT Male-Metric



Standpipe Adaptor  
BSPT Male-Imperial

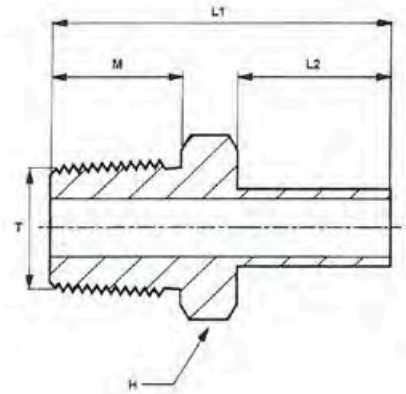

### STANDPIPE ADAPTOR BSPT MALE-METRIC

Part No	Standpipe Diameter	T BSPT Male	M Stud Length	L1 Length	L2 Length	H Hex A/F
MSA06/163	6	1/4	12.5	33	15.5	14
MSA08/163	8	1/4	12.5	34	16.5	14
MSA10/163	10	1/4	12.5	34.5	17	14
MSA10/243	10	3/8	13	35.5	17	19
MSA12/323	12	1/2	17	40.5	17	22

### STANDPIPE ADAPTOR BSPT MALE-IMPERIAL

Part No	Standpipe Diameter	T BSPT Male	M Stud Length	L1 Length	L2 Length	H Hex A/F
SA03/083	1/4	1/8	0.343	1.25	0.75	0.445
SA03/163	1/4	1/4	0.5	1.437	0.75	0.601

Every effort has been made to ensure that the information contained in this publication is accurate at the time of publishing. Wade assumes no responsibility or liability for typographical errors or omissions or for any misinterpretation of the information within the publication and reserves the right to change without notice.

# Compression Fittings

## HOSE TAILS

### FEATURES & BENEFITS

- A range of brass BSP taper male hose tail adaptors, swivel nut hose nozzle adaptors and hose repairers
- Providing a quick and easy connection with soft nylon, plastic and PVC tubing
- Designed for use with compressed air, water, oils and fluids on low pressure hydraulic and pneumatic applications
- The hose connection is made by pushing the end of the tube over the barbed hose tail stem, securing it into place with a jubilee clip or 'O'clip



Hose Tail Adaptor BSPT Male-Imperial

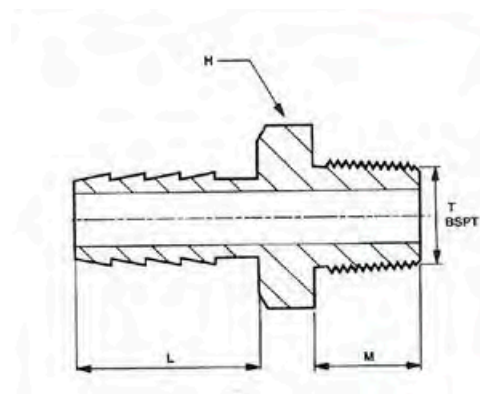

### HOSE TAIL ADAPTOR BSPT MALE-IMPERIAL

Part No	To Suit Hose Bore	T BSPT Male	M Length	L Length	H Hex A/F
HT01/083	3/16	1/8	8.5	23.5	11
HT03/083	1/4	1/8	8.5	23.5	11
HT05/083	5/16	1/8	8.5	23.5	11
HT08/083	3/8	1/8	8.5	23.5	11
HT01/163	3/16	1/4	12.5	23.5	14
HT03/163	1/4	1/4	12.5	23.5	14
HT05/163	5/16	1/4	12.5	23.5	14
HT08/163	3/8	1/4	12.5	23.5	14
HT11/163	1/2	1/4	12.5	34.5	17
HT03/243	1/4	3/8	13	23.5	17
HT05/243	5/16	3/8	13	23.5	17
HT08/243	3/8	3/8	13	23.5	17
HT11/243	1/2	3/8	13	34.5	17
HT13/243	5/8	3/8	13	34.5	17
HT03/323	1/4	1/2	17	23.5	22
HT05/323	5/16	1/2	17	23.5	22
HT08/323	3/8	1/2	17	23.5	22
HT11/323	1/2	1/2	17	34.5	22
HT13/323	5/8	1/2	17	34.5	22
HT14/323	3/4	1/2	17	34.5	22
HT11/483	1/2	3/4	18	34.5	27
HT14/483	3/4	3/4	18	34.5	27
HT17/483	1	3/4	18	34.5	27
HT14/643	3/4	1	21.5	34.5	36
HT17/643	1	1	21.5	34.5	36

Every effort has been made to ensure that the information contained in this publication is accurate at the time of publishing. Wade assumes no responsibility or liability for typographical errors or omissions or for any misinterpretation of the information within the publication and reserves the right to change without notice.

# Compression Fittings

## HOSE TAILS

### FEATURES & BENEFITS

- A range of brass BSP taper male hose tail adaptors, swivel nut hose nozzle adaptors and hose repairers
- Providing a quick and easy connection with soft nylon, plastic and PVC tubing
- Designed for use with compressed air, water, oils and fluids on low pressure hydraulic and pneumatic applications
- The hose connection is made by pushing the end of the tube over the Barbed hose tail stem, securing it into place with a jubilee clip or 'O'clip

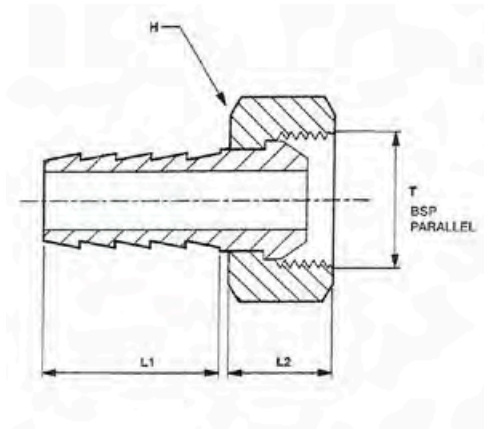

*Hose Nozzle Adaptor With BSP Female Swivel Nut-Imperial*

## HOSE NOZZLE ADAPTOR WITH BSP FEMALE SWIVEL NUT-IMPERIAL

Part No	To Suit Hose Bore	T BSP Female	L1 Length	L2 Length	H Hex A/F
HSW03/162	1/4	1/4	1	0.5	0.6
HSW05/162	5/16	1/4	1	0.5	0.6
HSW08/242	3/8	3/8	1	0.531	0.82
HSW11/322	1/2	1/2	1	0.593	1.011

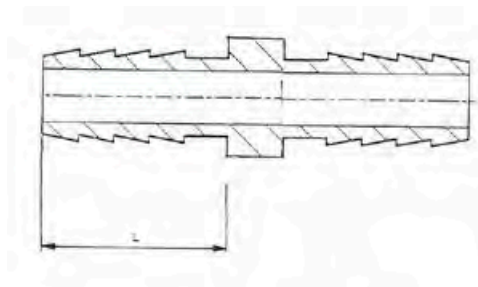

*Hose Repairer-Imperial*

## HOSE REPAIRER-IMPERIAL

Part No	To Suit Hose Bore	L Length
HREP/01	3/16	20
HREP/03	1/4	24.5
HREP/05	5/16	24.5
HREP/08	3/8	24.5
HREP/11	1/2	35
HREP/14	3/4	35
HREP/17	1	35

Every effort has been made to ensure that the information contained in this publication is accurate at the time of publishing. Wade assumes no responsibility or liability for typographical errors or omissions or for any misinterpretation of the information within the publication and reserves the right to change without notice.



# Compression Fittings

## HOSE TAILS

### FEATURES & BENEFITS

- A range of brass 'Fulham' rubber hose nozzle adaptors with BSP parallel male, BSP parallel female and BSP taper male stud thread connections
- Providing a quick and easy male or female stud thread connection with 3/8" inside diameter LPG rubber hose
- Enabling hose connection to mating BSP parallel BS2779, BSP taper or BSP parallel BS21 female threaded ports and BSP parallel male stud threads
- The hose connection is made by pushing the end of the tube over the hose tail stem, securing it into place with a jubilee clip or 'O'clip
- Designed for use on low pressure LPG and natural gas applications, particularly within the caravan and leisure industry



'Fulham' Rubber Hose Nozzle Adaptor  
BSP Parallel Male-Imperial



'Fulham' Rubber Hose Nozzle Adaptor  
BSP Parallel Female-Imperial



'Fulham' Rubber Hose Nozzle Adaptor-  
BSP Taper Male-Imperial

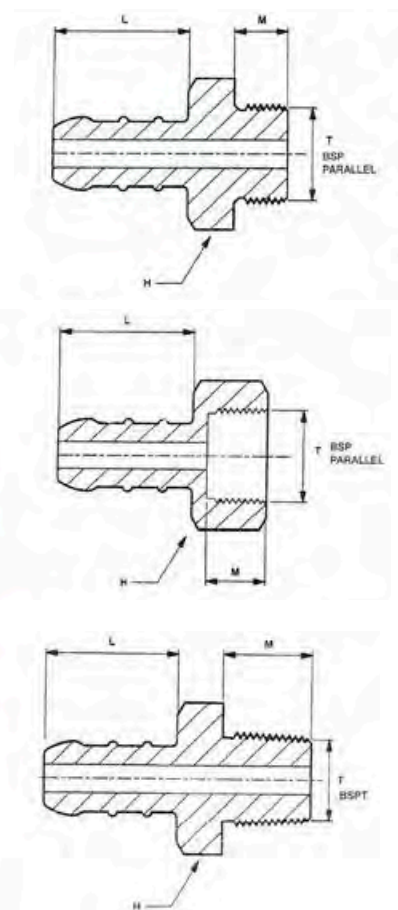

### 'FULHAM' RUBBER HOSE NOZZLE ADAPTOR BSP PARALLEL MALE-IMPERIAL

Part No	To Suit Hose Bore	T BSP Male	M Length	L Length	H Hex A/F
F100	3/8" (10mm)	1/8	0.35	0.93	0.445
F101	3/8" (10mm)	1/4	0.35	0.93	0.601
F105	3/8" (10mm)	3/8	0.375	0.93	0.71

### 'FULHAM' RUBBER HOSE NOZZLE ADAPTOR-BSP PARALLEL FEMALE-IMPERIAL

Part No	To Suit Hose Bore	T BSP Female	M Length	L Length	H Hex A/F
F102	3/8" (10mm)	1/8	0.359	0.93	0.445
F103	3/8" (10mm)	1/4	0.39	0.93	0.601
F104	3/8" (10mm)	3/8	0.421	0.93	0.82

### FULHAM' RUBBER HOSE NOZZLE ADAPTOR-BSP TAPER MALE-IMPERIAL

Part No	To Suit Hose Bore	T BSPT Male	M Length	L Length	H Hex A/F
F700	3/8" (10mm)	1/8	0.375	0.93	0.445
F701	3/8" (10mm)	1/4	0.437	0.93	0.525
F705	3/8" (10mm)	3/8	0.5	0.93	0.71

Every effort has been made to ensure that the information contained in this publication is accurate at the time of publishing. Wade assumes no responsibility or liability for typographical errors or omissions or for any misinterpretation of the information within the publication and reserves the right to change without notice.

# Compression Fittings

## HOSE TAILS

### FEATURES & BENEFITS

- A range of brass 'Fulham' rubber hose nozzle adaptors with compression ends to suit copper tube. The range includes a bulkhead option
- Providing a quick and easy copper tube connection with 3/8" inside diameter LPG rubber hose
- Enabling hose connection to mating BSP parallel BS2779, BSP taper or BSP parallel BS21 female threaded ports and BSP parallel male stud threads

- The hose connection is made by pushing the end of the tube over the hose tail stem, securing it into place with a jubilee clip or 'O'clip
- Designed for use on low pressure LPG and natural gas applications, particularly within the caravan and leisure industry

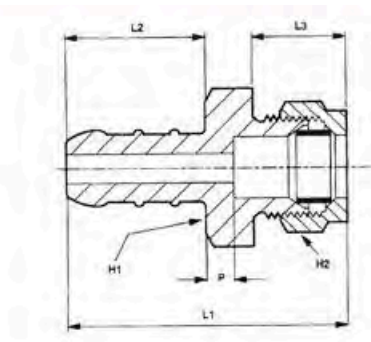

'Fulham' Rubber Hose Nozzle Adaptor-Imperial

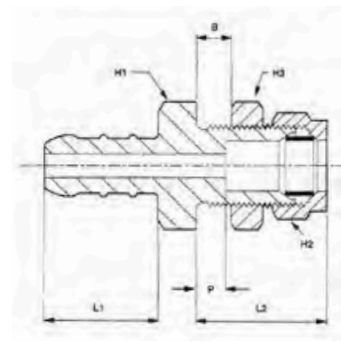

'Fulham' Rubber Hose Nozzle Bulkhead Adaptor-Imperial

### 'FULHAM' RUBBER HOSE NOZZLE ADAPTOR-IMPERIAL

Part No	To Suit Hose Bore	Tube OD.	L1 Length	L2 Length	L3 Length	H1 Hex A/F	H2 Hex A/F	P Abutment
F101A	3/8" (10mm)	1/4	1.761	0.93	0.531	0.601	0.601	0.275
F101A/5/16	3/8" (10mm)	5/16	1.885	0.93	0.655	0.601	0.601	0.275
F105A	3/8" (10mm)	3/8	1.823	0.93	0.593	0.71	0.82	0.25
F101/1011	3/8" (10mm)	1/2	2.007	0.93	0.777	0.92	0.92	0.175

### 'FULHAM' RUBBER HOSE NOZZLE BULKHEAD ADAPTOR-IMPERIAL

Part No	To Suit Hose Bore	Tube OD.	L1 Length	L2 Length	H1 Hex A/F	H2 Hex A/F	H3 Hex A/F	P Abutment	B Max Bulkhead	Bulkhead Hole Dia
F101/L4	3/8" (10mm)	1/4	0.93	1.125	0.71	0.601	0.71	0.437	1/4	0.531 (17/32")
F101/L4/5/16	3/8" (10mm)	5/16	0.93	1.125	0.71	0.601	0.71	0.437	1/4	0.531 (17/32")
F105A/L4	3/8" (10mm)	3/8	0.93	1.093	0.82	0.82	0.82	0.437	1/4	0.672 (43/64")

Every effort has been made to ensure that the information contained in this publication is accurate at the time of publishing. Wade assumes no responsibility or liability for typographical errors or omissions or for any misinterpretation of the information within the publication and reserves the right to change without notice.

# Compression Fittings

## COMPRESSION NUTS

### FEATURES & BENEFITS

- A range of imperial and metric brass compression nuts with BSP Parallel and metric female threads
- Designed for use with imperial and metric outside diameter plain copper and nylon tubes
- Specifically designed for use in combination with Wade bodies and compression rings, we cannot recommend interchangeability with other brands



Compression Nut-Imperial



Compression Nut-Metric

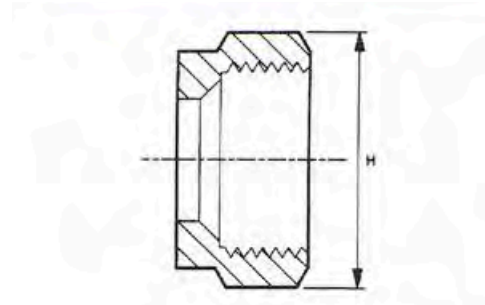

### COMPRESSION NUT-IMPERIAL

Part No	Tube OD.	Thread Size & Type	H Hex A/F
WUN1000	1/8	1/8" BSP	0.445
WUN1001	3/16	1/8" BSP	0.445
WUN1003	1/4	1/4" BSP	0.601
WUN1005	5/16	1/4" BSP	0.601
WUN1008	3/8	3/8" BSP	0.82
WUN1011	1/2	1/2" BSP	0.92
1013	5/8	3/4" BSP	1.2
1014	3/4	7/8" BSP	1.39
1017	1	1.461" X 11 WHIT	1.67

### COMPRESSION NUT-METRIC

Part No	Tube OD.	Thread Size & Type	H Hex A/F
WMUN104	4	M8 x 1	10
WMUN105	5	M10 x 1	12
WMUN106	6	M10 x 1	12
WMUN108	8	M12 x 1	14
WMUN110	10	M16 x 1.5	19
WMUN112	12	M18 x 1.5	22
MNI15	15	M20 x 1.5	24
MNI16	16	M22 x 1.5	27
MNI18	18	M24 x 1.5	30
MNI20	20	M27 x 1.5	32
MNI22	22	M30 x 1.5	36
MNI25	25	M33 x 1.5	41

Every effort has been made to ensure that the information contained in this publication is accurate at the time of publishing. Wade assumes no responsibility or liability for typographical errors or omissions or for any misinterpretation of the information within the publication and reserves the right to change without notice.

# Compression Fittings

## COMPRESSION NUTS

### FEATURES & BENEFITS

- A brass compression nut with BSP parallel male thread
- Designed for use with 1/4" od imperial outside diameter plain copper and nylon tube and female threaded seating. The seating dimensions, which can be machined into a unit or manifold block, are available on request.
- Specifically designed for use in combination with Wade compression rings, we cannot recommend interchangeability with other brands



Inner Nut-Imperial

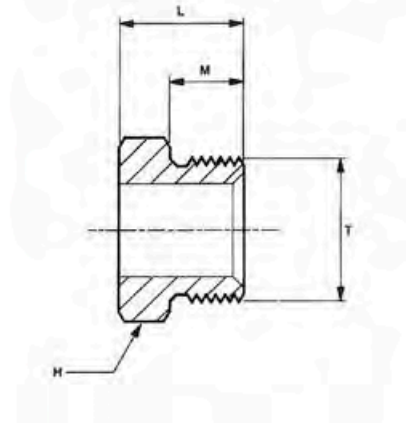

### INNER NUT-IMPERIAL

Part No	Tube OD.	T Thread	M Length	L Length	H Hex A/F
4003	1/4	1/4" BSP	0.312	0.5	0.525

### FEATURES & BENEFITS

- A range of brass compression nuts with BSP Parallel and metric parallel female threads
- Designed for use with imperial and metric outside diameter PVC covered copper and nylon tubes
- This original Wade design prevents atmospheric corrosion and contamination within the joint and also protects the ends of the outer PVC cover from damage
- Specifically designed for use in combination with Wade bodies and compression rings, we cannot recommend interchangeability with other brands



'Pc' Compression Nut For Pvc Covered Copper Tube-Imperial



'Pc' Compression Nut For Pvc Covered Copper Tube-Metric

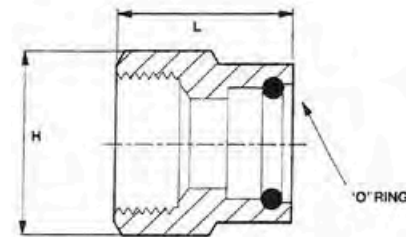

### 'PC' COMPRESSION NUT FOR PVC COVERED COPPER TUBE-IMPERIAL

Part No	Tube OD.	PVC Cover OD.	Thread Size & Type	L Length	H Hex A/F	P Abutment	'O' Ring
PC 1003	1/4	3/8	1/4" BSP	0.937	0.601	0.437	M308
PC 1008	3/8	1/2	3/8" BSP	1.093	0.82	0.562	M310
PC 1011	1/2	5/8	1/2" BSP	1.203	0.92	0.625	M312

### 'PC' COMPRESSION NUT FOR PVC COVERED COPPER TUBE-METRIC

Part No	Tube OD.	PVC Cover OD.	Thread Size & Type	L Length	H Hex A/F	P Abutment	'O' Ring
MN 406	6	9	M10 x 1	19	14	8	M531
MN 408	8	11	M12 x 1	20.5	17	8	M502
MN 410	10	13	M16 x 1.5	22.5	19	9.5	M503
MN 412	12	15	M18 x 1.5	25	24	12	M504

Every effort has been made to ensure that the information contained in this publication is accurate at the time of publishing. Wade assumes no responsibility or liability for typographical errors or omissions or for any misinterpretation of the information within the publication and reserves the right to change without notice.

# Compression Fittings

## COMPRESSION RINGS

### FEATURES & BENEFITS

- A range of annealed Copper compression rings designed for use with imperial and metric outside diameter plain copper and PVC covered copper tubes
- Specifically designed for use in combination with Wade bodies and compression nuts, we cannot recommend interchangeability with other brands



Copper Compression Ring-Imperial



Copper Compression Ring-Metric

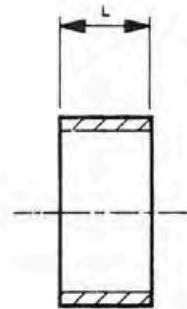

### COPPER COMPRESSION RING-IMPERIAL

Part No	Tube OD.	L Length
I020	1/8	0.218
I021	3/16	0.218
I023	1/4	0.25
I026	5/16	0.25
I028	3/8	0.281
I031	1/2	0.281
I033	5/8	0.343
I034	3/4	0.343
I036	7/8	0.406
I037	1	0.437

### COPPER COMPRESSION RING-METRIC

Part No	Tube OD.	L Length
MR206	6	6.5
MR208	8	6.5
MR210	10	7
MR212	12	7
MR215	15	7

### FEATURES & BENEFITS

- A range of Brass compression rings designed for use with imperial and metric outside diameter plain copper and nylon tubes
- Specifically designed for use in combination with Wade bodies and compression nuts, we cannot recommend interchangeability with other brands



Universal Compression Ring-Imperial and Universal Compression Ring-Metric



### UNIVERSAL COMPRESSION RING-IMPERIAL

Part No	Tube OD.	L Length
WURI020	1/8	0.189
WURI021	3/16	0.222
WURI023	1/4	0.23
WURI026	5/16	0.209
WURI028	3/8	0.272
WURI031	1/2	0.315

### UNIVERSAL COMPRESSION RING-METRIC

Part No	Tube OD.	L Length
WMURM4	4	4.8
WMURM5	5	5.3
WMURM6	6	5.3
WMURM8	8	5.3
WMURM10	10	7.2
WMURM12	12	7.2

Every effort has been made to ensure that the information contained in this publication is accurate at the time of publishing. Wade assumes no responsibility or liability for typographical errors or omissions or for any misinterpretation of the information within the publication and reserves the right to change without notice.



# Compression Fittings

## COMPRESSION RINGS

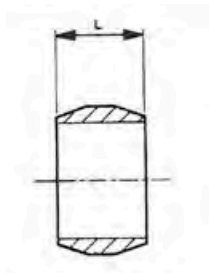

Brass Compression Ring-Imperial

### FEATURES & BENEFITS

- A range of brass compression rings designed for use with imperial outside diameter plain copper and PVC covered copper tubes
- Specifically designed for use in combination with Wade bodies and compression nuts, we cannot recommend interchangeability with other brands

### BRASS COMPRESSION RING-IMPERIAL

Part No	Tube OD.	L Length
499/0	1/8	0.218
499/1	3/16	0.218
499/3	1/4	0.25
499/5	5/16	0.25
499/8	3/8	0.281
499/11	1/2	0.312
499/13	5/8	0.312
499/14	3/4	0.406

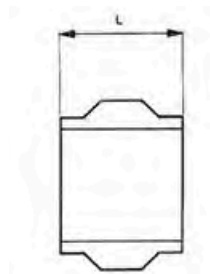

Brass Compression Ring-Metric (Type B)

### FEATURES & BENEFITS

- A range of brass compression rings designed for use with metric outside diameter plain copper and nylon tubes
- Please note that that; this option is not available for imperial outside diameter tubes
- Specifically designed for use in combination with Wade bodies and compression nuts, we cannot recommend interchangeability with other brands

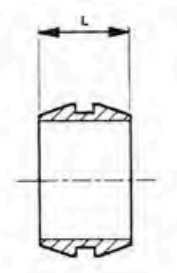

Brass Compression Ring-Metric (Type A)

### FEATURES & BENEFITS

- A range of brass compression rings designed for use with metric outside diameter plain copper and PVC covered copper tubes
- Specifically designed for use in combination with Wade bodies and compression nuts, we cannot recommend interchangeability with other brands

### BRASS COMPRESSION RING-METRIC (TYPE A)

Part No	Tube OD.	L Length
MURI04	4	5.5
MURI05	5	6
MURI06	6	6
MURI08	8	6.5
MURI10	10	7.5
MURI12	12	7.5
MURI14	14	8
MURI15	15	8
MURI16	16	8.5
MURI18	18	9
MURI20	20	9
MURI22	22	10
MURI25	25	10

### BRASS COMPRESSION RING-METRIC (TYPE B)

Part No	Tube OD.	L Length
MFR104/N	4	6
MFR105/N	5	6.5
MFR106/N	6	6.5
MFR108/N	8	7
MFR110/N	10	8
MFR112/N	12	8
MFR114/N	14	8.5

Every effort has been made to ensure that the information contained in this publication is accurate at the time of publishing. Wade assumes no responsibility or liability for typographical errors or omissions or for any misinterpretation of the information within the publication and reserves the right to change without notice.

# Compression Fittings

## COMPRESSION RINGS

### FEATURES & BENEFITS

- A range of Brass compression ferrules designed for use with imperial and metric outside diameter nylon tubes
- Specifically designed for use in combination with Wade bodies and compression nuts, we cannot recommend interchangeability with other brands



'N' Ferrule-Imperial



'N' Ferrule-Metric

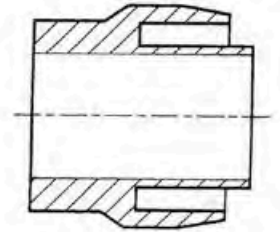

### 'N' FERRULE-IMPERIAL

Part No	Tube OD.	Tube ID.
<b>Light Gauge</b>		
NI020B/A	1/8	0.095
NI023B/A	1/4	0.19
NI025B/A	5/16	0.242
<b>Medium Gauge</b>		
NI021B/C	3/16	0.117
NI023B/C	1/4	0.17
NI025B/C	5/16	0.212
NI028B/C	3/8	0.265
NI028B/D	3/8	0.25
NI031B/C	1/2	0.35
<b>Heavy Gauge</b>		
NI020B/B	1/8	0.075
NI021B/B	3/16	0.107
NI023B/B	1/4	0.15

### 'N' FERRULE-METRIC

Part No	Tube OD.	Tube ID.
<b>Light Gauge</b>		
MNF706	6	4.5
MNF708	8	6
<b>Medium Gauge</b>		
MNF806	6	4
MNF808	8	5.5
MNF810	10	7
MNF812	12	8.5
MNF816	16	12

Every effort has been made to ensure that the information contained in this publication is accurate at the time of publishing. Wade assumes no responsibility or liability for typographical errors or omissions or for any misinterpretation of the information within the publication and reserves the right to change without notice.

# Compression Fittings

## 'P' TYPE JOINT – COMPRESSION RING, SPIGOT AND COMPRESSION NUT

### FEATURES & BENEFITS

- A range of Polythene compression rings designed for use with imperial outside diameter poly tubes
- Specifically designed for use in combination with Wade bodies, compression nuts and supporting spigots, we cannot recommend interchangeability with other brands

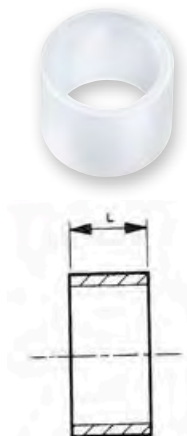

Polythene Compression Ring-Imperial

### FEATURES & BENEFITS

- A range of brass spigots designed for use with imperial outside diameter polytubes
- When inserted into the abutment of a standard Wade compression end, the spigot provides a support for the internal wall of the polytube, preventing collapse
- Specifically designed for use in combination with Wade bodies, compression nuts and rings, we cannot recommend interchangeability with other brands

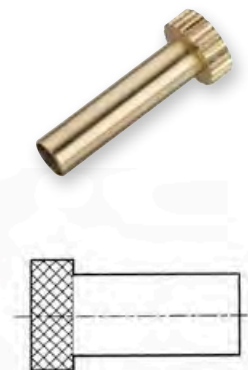

Knurled Spigot-Imperial

### POLYTHENE COMPRESSION RING-IMPERIAL

Part No	Tube OD.	L Length
P1023	1/4	0.29
P1028	3/8	0.29

### KNURLED SPIGOT-IMPERIAL

Part No	Tube OD.	Tube ID.
P1023B	1/4	0.156
P1028B	3/8	0.25

### FEATURES & BENEFITS

- A range of brass compression nuts with BSP Parallel female threads
- Designed for use with imperial outside diameter polytubes
- The knurled external face enables hand tightening to make the joint
- Specifically designed for use in combination with Wade bodies and compression rings, we cannot recommend interchangeability with other brands



Knurled Compression Nut-Imperial

### KNURLED COMPRESSION NUT-IMPERIAL

Part No	Tube OD.	Thread
P1003	1/4	1/4" BSP
P1008	3/8	3/8" BSP

Every effort has been made to ensure that the information contained in this publication is accurate at the time of publishing. Wade assumes no responsibility or liability for typographical errors or omissions or for any misinterpretation of the information within the publication and reserves the right to change without notice.

# Compression Fittings

## BLANKING SOLUTIONS



Blanking Nut-Imperial

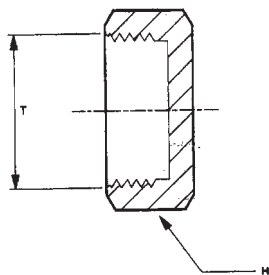

### FEATURES & BENEFITS

- A range of brass blanking nuts with BSP parallel female threads
- Designed to provide a blanking solution, sealing an imperial compression end on standard Wade brass compression fitting assemblies.
- Specifically designed for use with Wade bodies, we cannot recommend interchangeability with other brands
- Please note this option is not available for metric od compression ends

### BLANKING NUT-IMPERIAL

Part No	For Wade Compression End	Thread Size & Type	H Hex A/F
I001BL	1/8" OD. & 3/16" OD.	1/8" BSP	0.445
I003BL	1/4" OD. & 5/16" OD.	1/4" BSP	0.601
I008BL	3/8" OD.	3/8" BSP	0.82
I011BL	1/2" OD.	1/2" BSP	0.92



Blanking End-Imperial

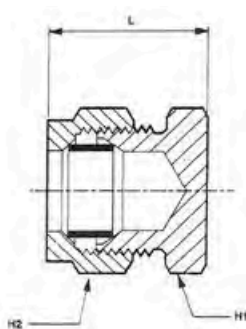

### FEATURES & BENEFITS

- A range of brass blanking ends with standard imperial od Wade compression ends
- Designed to provide a blanking solution, sealing sectioned or open lengths of imperial od copper and nylon tubes

### BLANKING END-IMPERIAL

Part No	Tube OD.	L Length	H1 Hex A/F	H2 Hex A/F
I103	1/4	0.718	0.525	0.601
I105	5/16	0.718	0.525	0.601
I108	3/8	0.812	0.71	0.82



Blanking Plug-Metric

### FEATURES & BENEFITS

- A range of solid brass blanking plugs
- Designed to provide a blanking solution, sealing a metric compression end on standard Wade brass compression fitting assemblies. By replacing the compression ring within an assembly the plug fills the void between the compression nut and body. The flow is blanked off by tightening the compression nut
- Specifically designed for use in combination with Wade bodies and compression nuts, we cannot recommend interchangeability with other brands
- Please note this option is not available for imperial od compression ends

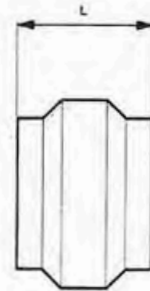

### BLANKING PLUG-METRIC

Part No	Tube OD.	L Length
MCP06	6	12.5
MCP08	8	13.5
MCP10	10	14.5
MCP12	12	14.5



Blanking End-Metric

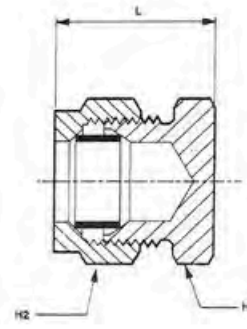

### FEATURES & BENEFITS

- A range of brass blanking ends with standard metric od Wade compression ends
- Designed to provide a blanking solution, sealing sectioned or open lengths of metric od copper and nylon tubes

### BLANKING END-METRIC

Part No	Tube OD.	L Length	H1 Hex A/F	H2 Hex A/F
MSE106	6	20	11	12
MSE108	8	22.5	13	14
MSE110	10	23.5	17	19
MSE112	12	24.5	19	22

Every effort has been made to ensure that the information contained in this publication is accurate at the time of publishing. Wade assumes no responsibility or liability for typographical errors or omissions or for any misinterpretation of the information within the publication and reserves the right to change without notice.

# Compression Fittings

## ACCESSORIES

### FEATURES & BENEFITS

- A range of brass locknuts with BSP Parallel and metric female threads
- Available as component parts these locknuts are also used on our Wade imperial and metric bulkhead coupling assemblies



Locknut-Imperial



Locknut-Metric

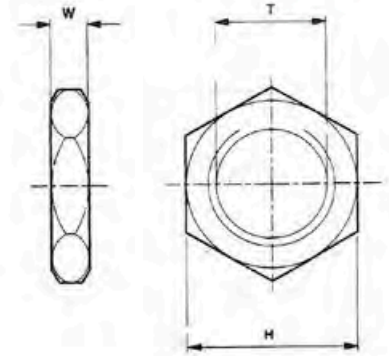

### LOCKNUT-IMPERIAL

Part No	T Thread	H Hex A/F	W Thickness
828/1	1/8" BSP	0.525	0.156
828/2	1/4" BSP	0.71	0.187
828/3	3/8" BSP	0.82	0.187
828/4	1/2" BSP	1.01	0.187
828/6	3/4" BSP	1.2	0.218
828/8	1" BSP	1.48	0.312

### LOCKNUT-METRIC

Part No	T Thread	H Hex A/F	W Thickness
ML10X10	M10 x 1	12	4
ML 12X10	M12 x 1	14	4
ML16 X 15	M16 x 1.5	19	5
ML18X15	M18 x 1.5	22	5
ML20 X 15	M20 x 1.5	24	5
ML30X15	M30 x 1.5	36	7

Every effort has been made to ensure that the information contained in this publication is accurate at the time of publishing. Wade assumes no responsibility or liability for typographical errors or omissions or for any misinterpretation of the information within the publication and reserves the right to change without notice.

# Compression Fittings

## ACCESSORIES

### FEATURES & BENEFITS

- A range of imperial and metric annealed copper sealing washers
- Designed to create a seal between mating BSP Parallel and metric, male and female stud threads where pressure-tight joints are not made on the threads



Copper Washer-Imperial



Copper Washer-Metric

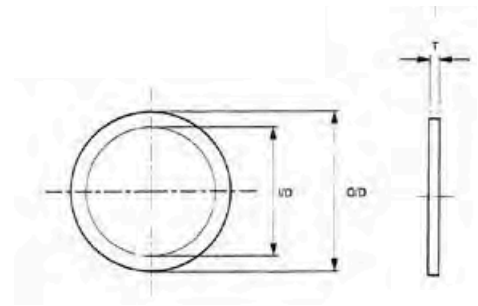

### COPPER WASHER-IMPERIAL

Part No	To Suit Thread Size & Type	OD.	ID.	T Thickness
M351	1/8" BSP Male & 3/8" BSP Female	0.58	0.393	0.062
M352	1/4" BSP Male & 1/2" BSP Female	0.72	0.527	0.062
M353	3/8" BSP Male & 3/4" BSP Female	0.925	0.675	0.062
M354	1/2" BSP Male & 7/8" BSP Female	1.093	0.83	0.062
M355	5/8" BSP Male & 1" BSP Female	1.187	0.91	0.093
M359	1-1/8" BSP Male & 1-1/2" BSP Female	1.761	1.505	0.093
M356	3/4" BSP Male	1.25	1.05	0.093
M357	7/8" BSP Male	1.38	1.2	0.093
M358	1" BSP Female	1.53	1.32	0.093
M362	1/8" BSP Female	0.33	0.187	0.031
M363	1/4" BSP Female	0.437	0.263	0.062
M364	5/8" BSP Female	0.8	0.64	0.062

### COPPER WASHER-METRIC

Part No	To Suit Thread Size	To Suit Alternative Thread Size	OD.	ID.	T Thickness
MW2/8M	8mm Male	N/A	11	8.3	1
MW2/10M	10mm Male	1/8" BSP Male	13.5	10.3	1
MW2/12M	12mm Male	N/A	15.5	12.3	1.5
MW2/14M	14mm Male	1/4" BSP Male	18	14.2	1.5
MW2/16M	16mm Male	N/A	20	16.2	1.5
MW2/22M	22mm Male	N/A	27	22.3	1.5

Every effort has been made to ensure that the information contained in this publication is accurate at the time of publishing. Wade assumes no responsibility or liability for typographical errors or omissions or for any misinterpretation of the information within the publication and reserves the right to change without notice.



# Compression Fittings

## ACCESSORIES

### FEATURES & BENEFITS

- A range of 2 and 3 piece brass reducing sets
- The reducing set enables the adaptation of a standard Wade metric compression end for use with a smaller outside diameter metric tube



*Tube Reducing Set-2 Piece-Metric*



*Tube Reducing Set-3 Piece-Metric*

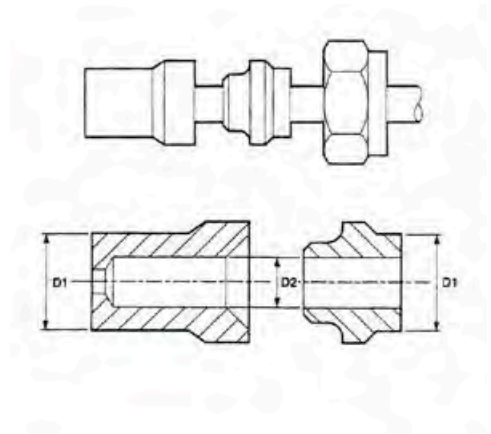

### TUBE REDUCING SET-2 PIECE-METRIC

Part No	D1 Diameter	D2 Diameter
MRA06/104	6	4
MRA08/106	8	6
MRA10/106	10	6
MRA10/108	10	8
MRA12/108	12	8
MRA12/110	12	10

### TUBE REDUCING SET-3 PIECE-METRIC

Part No	D1 Diameter	D2 Diameter
GMRA12/108	12	8
GMRA15/108	15	8
GMRA15/110	15	10
GMRA15/112	15	12
GMRA22/112	22	12
GMRA22/115	22	15
GMRA28/108	28	8
GMRA28/112	28	12
GMRA28/115	28	15
GMRA28/122	28	22

Every effort has been made to ensure that the information contained in this publication is accurate at the time of publishing. Wade assumes no responsibility or liability for typographical errors or omissions or for any misinterpretation of the information within the publication and reserves the right to change without notice.

# Compression Fittings

## ACCESSORIES

### FEATURES & BENEFITS

- A range of nylon tube clips
- These tube clips enable both single and multiple tubes of the same outside diameter to be secured to a wall, panel or floor

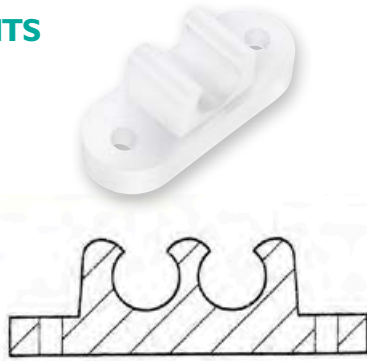

Nylorack Tube Clips-Imperial & Metric

### FEATURES & BENEFITS

- A range of mild steel, zinc plated tube clips
- 'O' clips are suitable for use on lower pressure applications enabling the securement of flexible PVC hose over barbed hose tail ends



'O' Clips-Imperial & Metric

## NYLORACK TUBE CLIPS-IMPERIAL & METRIC

Part No	Type	To Suit Tube OD. Size
N6/1	1 Way	3/16" & 4mm
N8/1	1 Way	1/4" & 6mm
N10/1	1 Way	5/16" & 8mm
N12/1	1 Way	3/8" & 10mm
N16/1	1 Way	1/2" & 12mm
N6/2	2 Way	3/16" & 4mm
N8/2	2 Way	1/4" & 6mm
N10/2	2 Way	5/16" & 8mm
N12/2	2 Way	3/8" & 10mm
N16/2	2 Way	1/2" & 12mm
N6/3	3 Way	3/16" & 4mm
N8/3	3 Way	1/4" & 6mm
N10/3	3 Way	5/16" & 8mm
N12/3	3 Way	3/8" & 10mm
N6/4	4 Way	3/16" & 4mm
N8/4	4 Way	1/4" & 6mm
N6/5	5 Way	3/16" & 4mm
N12/5	5 Way	3/8" & 10mm
N8/10	10 Way	1/4" & 6mm

## 'O' CLIPS-IMPERIAL & METRIC

Part No	To Suit Tube OD. Size
OC3	3/16" & 4mm
OC4	1/4" & 6mm
OC5	5/16" & 8mm
OC6	3/8" & 10mm
OC7	7/16" & 11mm
OC8	1/2" & 12mm
OC9	9/16" & 14mm
OC10	5/8" & 16mm
OC12	3/4" & 19mm
OC14	7/8" & 22mm
OC16	1" & 25mm

Every effort has been made to ensure that the information contained in this publication is accurate at the time of publishing. Wade assumes no responsibility or liability for typographical errors or omissions or for any misinterpretation of the information within the publication and reserves the right to change without notice.



To visit our Video Library go to:  
[www.youtube.com/user/CraneBSU](http://www.youtube.com/user/CraneBSU)



# Wade™

CRANE HOUSE, EPSILON TERRACE  
WEST ROAD, IPSWICH  
SUFFOLK, IP3 9FJ,  
UNITED KINGDOM  
TELEPHONE: +44 (0)1473 277460  
FAX: +44 (0)1473 277411  
EMAIL: [wadesales@cranebsu.com](mailto:wadesales@cranebsu.com)

[www.wadefittings.com](http://www.wadefittings.com)



FM311  
ISO 9001

- Designed and manufactured under quality management systems in accordance with BS EN ISO 9001-2008

Every effort has been made to ensure that the information contained in this publication is accurate at the time of publishing. Wade assumes no responsibility or liability for typographical errors or omissions or for any misinterpretation of the information within this publication and reserves the right to change without notice. We hope that our communications have an impact on you, but not on the environment. We have taken steps to ensure this leaflet is printed on FSC material and the paper is made by a totally chlorine free process.

W\_CFPD\_07\_2016